

*The*

# SenzTx

**Zirconia Oxygen Analyzer**

WITH 4-20mA ANALOGUE OUTPUT

**Short Form user Manual**



## Table of Contents

1.1.	General Information.....	3
1.1.2	Intended Use of the SenzTx.....	3
1.1.3	The Measuring Cell/Sensor Element .....	3
1.1.4	Unintended Use of the SenzTx Analyzer .....	4
1.1.5	Construction .....	4
1.1.6	Calibration of the Measuring Instruments.....	4
1.2.	Technical Description.....	5
1.2.1	Connection .....	5
1.2.2	Technical Data.....	5
1.2.3	Installation.....	7
1.3.	Maintenance and Calibration of Measuring Cells.....	9
	Appendices .....	10

## **1.1. General Information**

---

### **1.1.2 Intended Use of the SenzTx**

The Analyzer are designed to monitor a sample containing an oxygen content to be measured within the specified ppm or % ranges.

The Analyzer can be used in combination with the control system (PLC) or as a standalone oxygen-measuring-system.

### **1.1.3 The Measuring Cell/Sensor Element**

This Analyzer uses a semiconductor measuring cell made of Zirconium dioxide and is specific to oxygen. Due to the high temperature and the catalytic activity of the platinum coating of the sensor it has low cross-sensitivities to other gasses. The benefits of this technology give a long sensor life, typically 5 years or more however it should be noted that exposure to aggressive gaseous substances can reduce the operational life of the sensor.

### 1.1.4 Unintended Use of the SenzTx Analyzer

The Analyzer can also be used in other applications outside of those described in this manual. However, the user should check with the manufacture beforehand.

	<b>CAUTION</b>
	<b>Risk of damage!</b> The SenzTx Analyzer should only be operated in the way set out in this manual.

### 1.1.5 Construction

The **SenzTx Zirconia** Oxygen Analyzer consists of a measuring cell and associated electronics, separated by a gastight clamp flange. The measuring cell (sensor) is mounted within a metal bracket, provided with a thread for easy changing of the measuring cell. The measuring cell is connected with the electronics by a vacuum-tight arrangement. The electronics is arranged in a metal housing, which is mounted directly on a flow through adapter. The Analyzer is powered by 24VDC and provides an analogue output signal of 4-20mA and other additional interface signals. See section 1.2.1 for specific information.

### 1.1.6 Calibration of the Measuring Instruments

The equipment is calibrated before shipping. The calibration cycles are dependent on the application and the applied gases.

	<b>Note!</b>
	<b>Though the SenzTx Zirconia Sensor is a very stable instrument, Ntron recommends a calibration check be made at least annually by suitably trained technicians. If it is determined that a re-calibration is required, please contact Ntron for details. Calibration is not within the scope of this manual.</b> <b>After changing of measuring cells a recalibration is mandatory.</b>

Electronics and measuring cell are calibrated with certified calibration gases by the manufacturer; there are no setting options available for the user.

## 1.2. Technical Description

---

### 1.2.1 Connection

The Oxygen measurement equipment is connected by a M12x1mm threaded-connecting plug (8pin).

**Pin Assignment:**

Pin-No.	Contact	Cable colour
1	Not used	N/A
2	Not used	N/A
3	4-20mA output Ground	Green
4	Serial RS485 (B)	Yellow
5	Serial RS485 (A)	Grey
6	Power Ground OVDC	White
7	Supply +24 VDC	Blue
8	4-20mA Output	Red

Industry standard 4-20mA interface required. Active 4-20mA output from the Senz Tx

### 1.2.2 Technical Data

<b>Mechanical Data</b>	Dimensions:	Ø47mm x 143mm(L)(Depends on model)
	Process Connection	Typically 1/8" (F)NPT (Flow Through base)
	Weight:	0.260 kg
<b>Electrical Data</b>	Supply Voltage:	24 VDC ± 10%, max. 50mA
	Protection Class:	IP 53
<b>Environment</b>	Ambient temperature:	+5 to +50 ° C
	Pressure:	800 to 1200 mbar <i>(Differential pressure between Analyzer and electronics max. =100 mbar)</i>
	Volumetric flow-rate:	0.25 LPM ± 10% recommended
<b>Measuring</b>	Range:	0-1000ppm, 0-25%
	Sensitivity:	0.01% O2
	Response time (0 - 90 %):	< 5Hours to 1ppm for ppm range. <3minutes for % range..
	Warming up time:	10 minutes

	Cell Life <sup>1)</sup> :	3-5 Years
	Cross sensitivities	none for normal applications (no aggressive gases)

1) In absence of reactive gases.

2) Sensor life is typical but dependent on many factors. *(See also chapter 1.1. Intended Use).*

1.2.3 Installation

	<p><b>Note!</b></p> <p>Before connecting voltage, the SenzTx Oxygen Analyzer should be exposed to inert gas for at least 1 minute.</p>
---	--

<p><b>CAUTION</b></p>	
	<p><b>Risk of damage!</b></p> <p>The SenzTx Zirconia Oxygen Analyzer should not be subjected to moisture in the sample gas stream when cold (not powered). It is advised that any moisture and other contaminants are removed from the sample gas stream prior to entering the SenzTx measurement stream.</p>

Typical connection diagram.

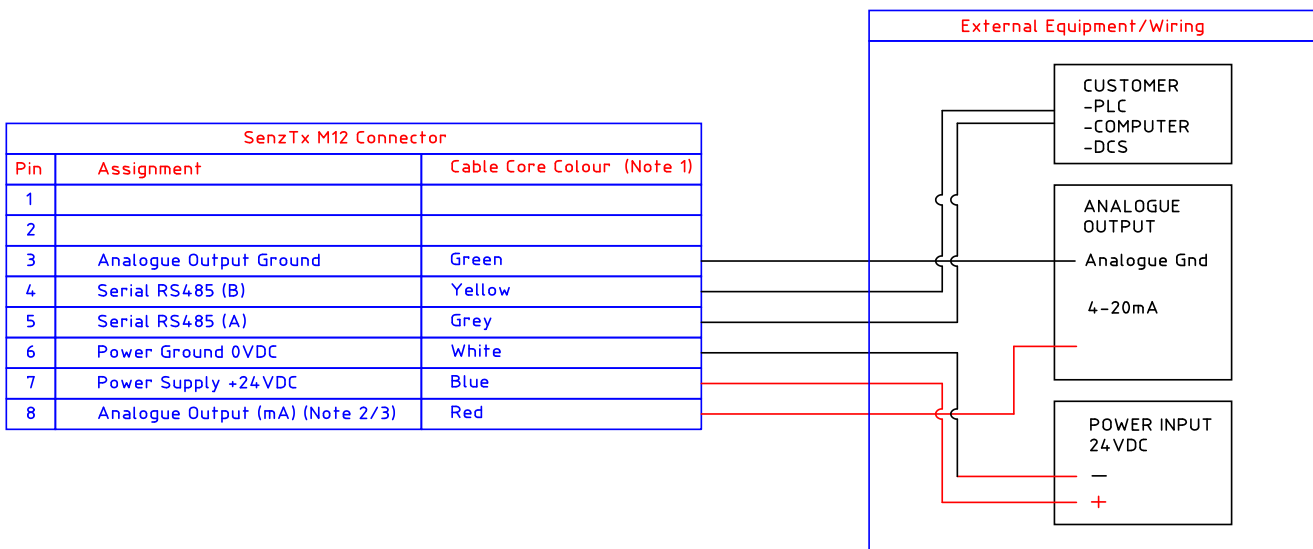

Note: any unused cable cores must be suitable insulated

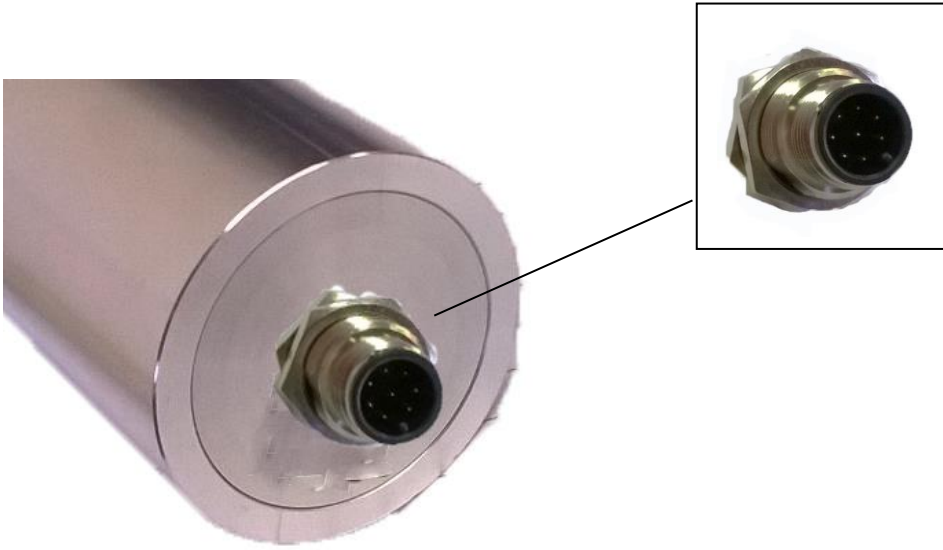

**M12 connector**



### 1.3. Maintenance and Calibration of Measuring Cells

---

All **SenzTx** Oxygen Analyzers undergo a certified calibration before shipping.

User calibration is not within the scope of this manual

## Appendices

The following pages contain installation and connection drawings for the Flow Through Base type SenzTx. Though this manual covers the Zirconia model SenzTx, connections for Electrochemical models are also given on page 11 for comparison purposes.

Page 12 details an example of a piping system for the application of the correct pressures and flow rates of a gas to be sampled by the Zirconia model SenzTx.

Note, this example is for a flow base without integral orifice.

(For models with an integral Orifice in the flow base , the sample gas pressure is to be presented at a set amount of 2Barg and this automatically produces the correct flow rate through the SenzTx)

# Electrical and Sample gas connection information.

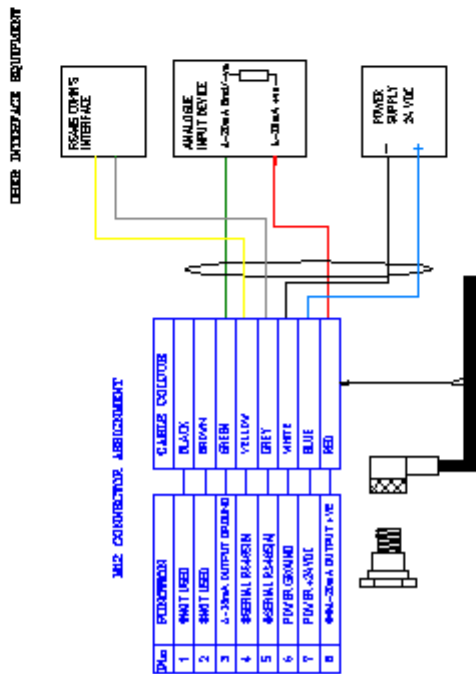
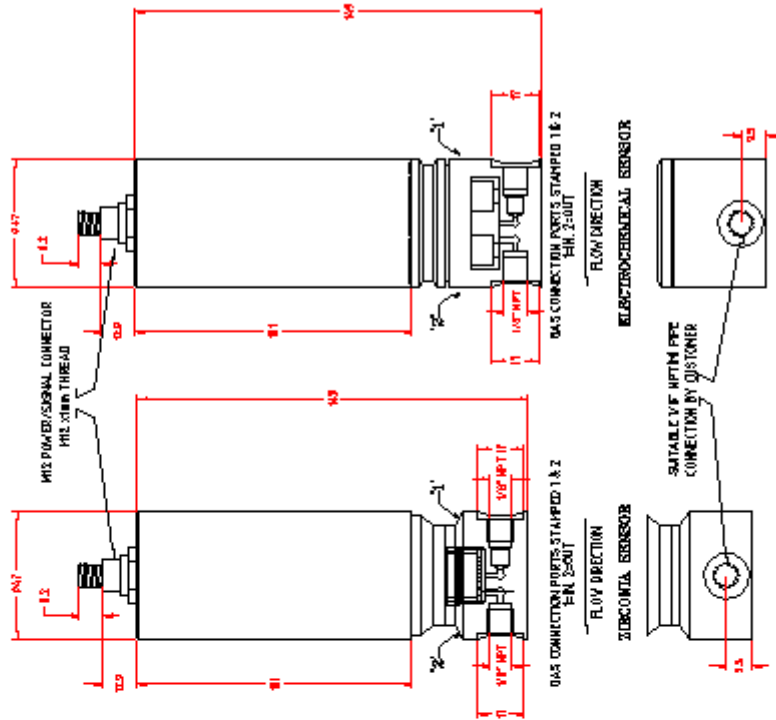

1MTR CABLE WITH M12 CONNECTOR SUPPLIED AS STANDARD.  
 #USER TO SUITABLY INSULATE ANY UNUSED WIRES.  
 RS485 IS AVAILABLE IF REQUIRED BY USER.  
 ## THE 4-20mA IS A SOURCE OUTPUT.

**APPLICATION NOTES:**

THE SENSITIVITY SHOULD BE INSTALLED VERTICALLY IF POSSIBLE (CONNECTOR UPPERMOST)  
 SAMPLE GAS FLOW RATE SHOULD BE REGULATED TO APPROX. 250ml/min.  
 (NOTE: WHEN SUPPLIED WITH INTEGRAL FLOW CONTROL ORIFICE, THE SAMPLE GAS PRESSURE SHOULD BE APPROX. 2BARG TO PRODUCE THE REQUIRED FLOW OF APPROX. 250ml/min)  
 SAMPLE GAS PRESSURE PRESENTED TO THE SENSITIVITY SHOULD BE WITHIN +/- 10% AMBIENT (TYPICALLY FOR AMBIENT PRESSURE OF 1013mb ABSOLUTE)  
 FOR ZIRCONIA SENSITIVITY MODELS, THE SAMPLE GAS MUST NOT CONTAIN H2S OR HCL.  
 SUCH GASES MAY CAUSE IRREPARABLE DAMAGE TO THE SENSING ELEMENT.  
 WETTING OF THE SENSOR ELEMENT BY CONDENSATES IN THE SAMPLE GAS STREAM SHOULD BE AVOIDED.  
 IF WETTING OF THE SENSOR WHILE IN UN-POWERED STATE IS SUSPECTED, DO NOT TURN POWER ON UNTIL A DRY GAS (e.g. N2) HAS BEEN FLOWED THROUGH THE SENSOR TO DRY OUT AND REMOVE ANY MOISTURE OR LIQUID TURNING ON THE SENSOR WITH MOISTURE PRESENT ON THE SENSOR ELEMENT WILL IRREPARABLY DAMAGE THE SENSOR ELEMENT

# Example of Sample gas piping circuit (No integral orifice)

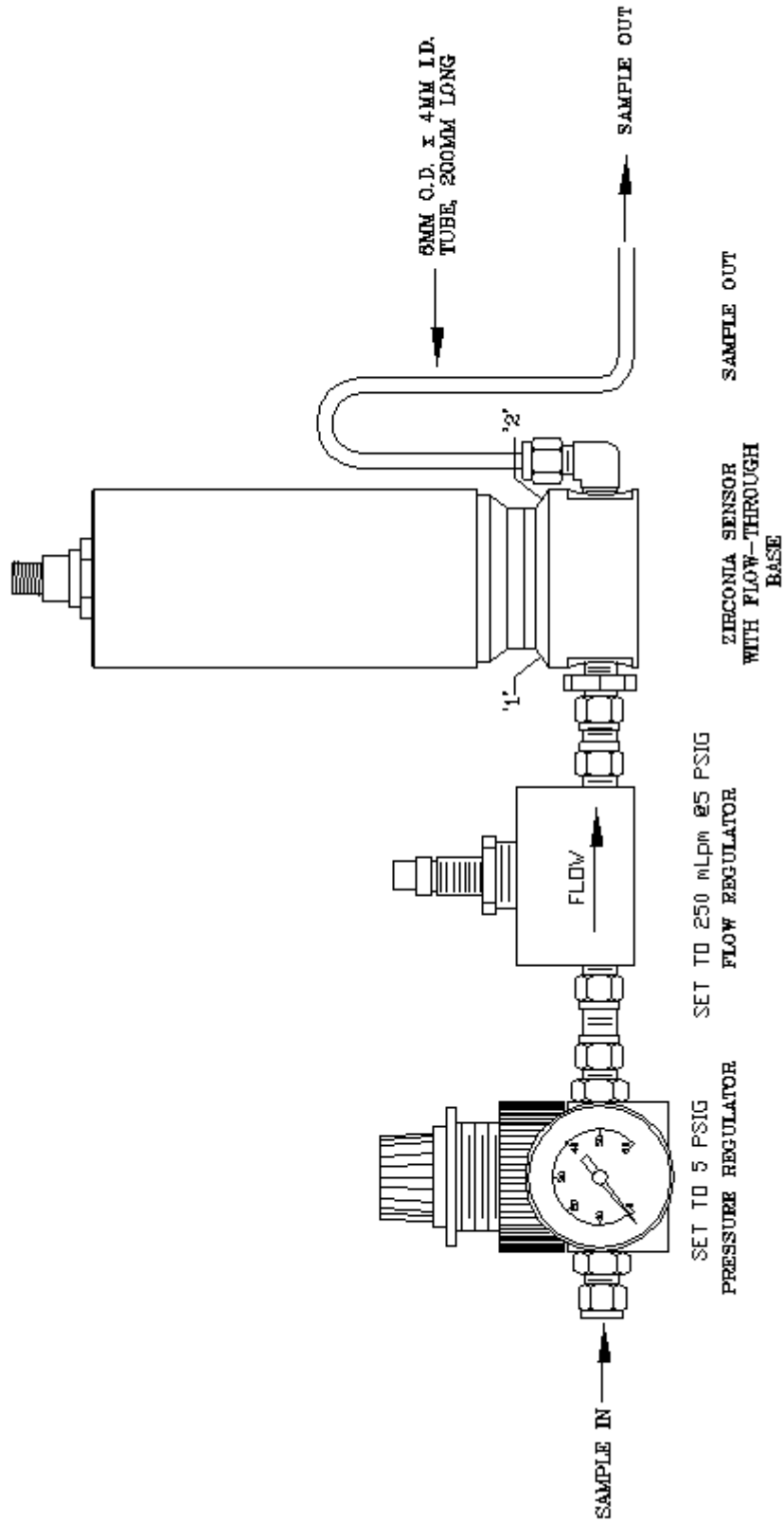

Ntron Ltd.  
Mullaghboy Industrial Park,  
Navan, Co. Meath, Ireland C15 XD61  
Tel:00353469071333; Fax:00353469071331;  
email:info@ntron.com; web: www.ntron.com