



OPERATING AND MAINTENANCE MANUAL

Oil-free screw compressor

KOMPBERG ZX55



Ladies and Gentlemen,

We heartily welcome you among our valued Customers and thank you for your trust to purchase the BERG compressor.

We are sure you will be fully satisfied with both the choice you have made and the cooperation you started with us. Our compressors are machines of top quality, which is the guarantee for a long years and reliable performance.

Our sales and service staff is available to answer all your queries regarding the installation and operation of your compressor. You are also encouraged to use our warranty and post-warranty technical service.

1. Information concerning the document	4
1.1. Scope and intended use of the manual	4
1.2. Intended use of the compressor and conditions of safe use	4
1.3. Qualification requirements for operation of the compressor	5
1.4. Operation	5
1.5. Other remarks and instructions.....	6
1.6. Warranty	6
2. Operating safety rules	6
2.1. Basic requirements for safe transport and positioning of the screw compressor	7
2.2. Operating safety requirements	8
2.3. Other hazards	8
2.4. Meaning of pictograms.....	9
3. Technical data.....	9
4. Setting	10
4.1. Room requirements.....	10
4.2. Requirements concerning electrical system.....	11
4.3. Compressed air connection	11
5. Screw compressor operating description	12
5.1. Screw compressor KOMPBERG ZX55 – operating description	12
Technological diagram.....	14
6. Start-up	17
6.1. Start-up preparation	17
6.2. Restart (after longer downtime).....	18
7. Maintenance	19
7.1 General requirements	19
7.2. Maintenance and checks	20
7.2.1 Maintenance at the beginning of compressor use, after oil and drive belts (if present) change	20
7.2.2 Daily maintenance	20
7.2.3 Periodic maintenance	20
7.2.4 Warranty and post-warranty checks	20
7.3. Basic components requiring maintenance. Maintenance operations	21
7.3.1. Air filter cartridge.....	21
7.3.2 Cleaning or replacing the filter mats.	21
7.3.3. Oil filter	22
7.3.4. Oil level	22
7.3.5 Changing oil	23
7.3.6. Handling wastes produced while operating the compressor	24
7.3.7 Oil cooler (exchanger) / interstage / final air	24
7.3.8. . Electric motor.....	25
7.3.9 Safety valve.....	25
8. Troubleshooting.....	27
9. Consumables for one year guarantee	30
10. Electrical scheme	30

1. Information concerning the document

This operating and maintenance manual is an integral part of the machine. It includes the information necessary to start, operate and maintain the compressor and requirements for its safe operation.

Following the manual rules will help you:

- Avoid hazards,
- Reduce repair costs and downtime,
- Increase the machine reliability and life.

Getting familiar with this manual in detail, using the machine in accordance with descriptions included in it and following all safety conditions are the basis for correct and safe operation of the machine.

In addition to the operating and maintenance manual and the regulations applied in the country of destination and health and safety at work regulations applied locally at the workstation, the generally recognised technical rules for safe and correct work are also valid.

1.1. Scope and intended use of the manual

The operating and maintenance manual is intended for qualified / suitably trained operating personnel of the compressor. The personnel assigned to operation of the compressor must, before starting work, get familiar with the manual contents, in particular the “Health and safety at work regulations” section.

The manual includes

- Description of daily service and maintenance of the compressor and control system,
- Technical documentation of the electrical part. It includes the data necessary to perform correct connections and repairs of the electrical equipment,
- Technical documentation of the mechanical part. It includes the data necessary to perform repairs of the mechanical equipment,
- Technical documentation of the control system. It includes the data necessary to switch on and off, and set operating parameters of the compressor.

The qualified personnel is understood to be the persons who because of received training, experience and knowledge of important standards, documentation and regulations concerning safety and operating conditions were authorised to carry out necessary operations and are able to recognise and avoid possible hazards.

1.2. Intended use of the compressor and conditions of safe use

The compressor is designed to produce only compressed air. It should be installed in accordance with the stipulations concerning the compressor installation and connection. The compressor must not be used for any other purposes that are non-compliant with its intended use. The manufacturer shall not be liable for any damage resulting from that reason. In that case, the risk is born by the machine user only.

During the compressor operation, you must follow the procedures given in the “Maintenance” section as regards scope and frequency of maintenance work and materials to be used.

Warning about forbidden use

- The compressor must not be used for any other purposes that are non-compliant with its intended use.
- Under no circumstances must the limit operating parameters of the compressor be exceeded and changed - refer to section 10 "Technical data".
- To use it for compression of other gases than air, it is required to obtain the manufacturer's consent. The above consent must be in written form.
- The compressor must not be used in potentially explosive atmospheres within the meaning of Directive 2014/34/UE.
- The compressor must not suck any toxic, acid-containing, flammable or explosive gases and vapours.
- Never direct a jet of compressed air at people or animals.

Safe use of the compressor

- The compressor must be operated in accordance with all guidelines included in this operating and maintenance manual.
- The sucked air must be clean and must not contain any harmful substances.
- The heated cooling air may be used for heating purposes if only its harmfulness to people and animals is excluded. Otherwise, it is necessary to provide the appropriate treatment of cooling air.
- Compressed air may only be used for breathing after its appropriate treatment.
- Compressed air not subjected to the appropriate treatment must not be used in production processes in which there is contact of air with food.



The compressor delivered is designed to compress only air. To use it for compression of other gases, it is required to obtain the manufacturer's consent. The above consent must be in written form. The compressor must not be used for any other purposes that are non-compliant with its intended use.



Fulfil the obligation to register the compressor air receiver in the Office of Technical Inspection (UDT). The compressor documentation is accompanied by the set of the required documentation of the air receiver (if applicable) and safety valve.

1.3. Qualification requirements for operation of the compressor.

The personnel who installs, operates and maintains the compressor should have the appropriate education and qualifications enabling safe operation of electro technical and electrical equipment.

Installation, operation and maintenance of the compressor may only be carried out by the persons who are familiar with this operating and maintenance manual, follow instructions included in it, know safety regulations and recognised technical rules.

1.4. Operation

While operating the compressor:

- Observe the instructions provided in the Operating and Maintenance Manual and Warranty Book.
 - Follow the periodic inspection schedule during both warranty period and after its completion. Regular performance of periodic inspections is necessary to ensure the required reliability and life of the BERG equipment. The inspections performed according the schedule reduce the number of repairs and their cost.
 - The technical and operating inspections should be carried out in accordance with the schedule and conditions by the factory service or authorised service, using the manufacturer's consumables and spare parts.
-

- During the warranty period, use only the manufacturer's consumables and spare parts.



The detailed list of maintenance operations can be found in the "Maintenance and inspections" section.

1.5. Other remarks and instructions

- This Operating and Maintenance Manual provides all information on how to install, start and operate the compressor. This manual should also be used when any maintenance work is carried out,
- The Manual should be read and always available to the compressor operator,
- During the maintenance work and periodic inspections, the provisions of the Warranty Book should be observed,
- The Maintenance section provides all measures and requirements necessary to keep the compressor in a correct technical state,
- Record all operating data, maintenance operations performed etc. into the Warranty Book. Observe all reference and local safety regulations relating to the compressor, including those listed herein and in the following sections,
- Failure to follow the requirements included in this Operating and Maintenance Manual and Warranty Book and/or unauthorised changes in the compressor or its integral units delivered by us shall make the warranty null and void.
- During warranty period, any repairs must be performed by the manufacturer service or authorised service centre listed in the Warranty Book.

1.6. Warranty

BERG Kompressoren GmbH. Spedition Straße 21, 40221 Düsseldorf Germany hereinafter referred to as the Warrantor provides the warranty for the products sold, ensures correct operation of the offered products provided that they are used in accordance with their intended use and operating conditions specified in this documentation.

The Purchaser shall lose its warranty rights for the product when:

- The machine is used in a way non-compliant with its intended use,
- Unauthorised modifications are carried out on the product,
- Interventions are carried out by unauthorised persons,
- Any repair attempts are carried out by unauthorised persons,
- The obligation to carry out periodic inspections is not observed,
- Non-original consumables are used.



The manufacturer reserves the right to make modifications in the product, resulting from continuous technical development, without prior notice.

2. Operating safety rules

The present rules are valid for BERG screw compressors. In addition to the general health and safety at work and the Office of Technical Inspection (UDT) regulations applicable to compressors, their assemblies and accessories, the safety instructions given below should be followed in particular. The operators are supposed to observe safe work practices. It is the user's responsibility to continuously maintain the compressor fully operable. Components and equipment considered to be no longer suitable for safe operation should be promptly replaced. Adjustments, installation, operation, maintenance and servicing should be entrusted only to properly trained, qualified and authorized staff.

The limit values (pressure, temperature, time settings etc.) are given in the Technical Data section.



The limit values may not be changed by the user.

The manufacturer accepts no responsibility for any personal injuries, damage of equipment or the compressor itself, at present and in the future, resulting from user's negligence and failure to observe the installation, operation and maintenance requirements contained herein. No responsibility is also taken for failure to observe valid safety standards relating to the equipment and qualified staff.

2.1. Basic requirements for safe transport and positioning of the screw compressor

In addition to the general health and safety at work and the Office of Technical Inspection (UDT) regulations, the following rules must be observed:

- Use only the lifting equipment that is compliant with the H&S and UDT regulations to lift the compressor. Fix in place all rotating or loose parts of the machine before its lifting. It is strictly forbidden to stay in the hazardous zone of the lifting equipment operation. The compressor movement can be accelerated or slowed down only within the permissible limits.
- When the compressor is transported, the transport straps should be pulled under the machine and secured above the housing in such a way that they do not place pressure on it. If the transport harness is fastened and secured incorrectly, the machine may get damaged.
- The compressor must be transported only with a forklift.
- Fasten the compressor frame with cargo straps to appropriate holders on the vehicle platform to prevent it from sliding or overturning.
- All screw and pipe connections should be of appropriate size and designed for a given operating pressure.
- The compressor is not designed to operate outdoors; it cannot be exposed to weather conditions.
- The compressor should be positioned in a closed room, where ambient air is cool and clean. Never block air flow to and from the room. Ensure sufficient inflow of cooling air and discharge of hot air outside the room. Temperature in a room with the compressor should be within the range of + 5°C to + 40°C.
- The air sucked in should contain no vapours or flammable gases, e.g. paint thinners, that might cause internal fire.
- There can be no objects close to the air inlet that could be sucked in with a jet of air.
- The pressure conduit connecting the compressor with the compressed air line should allow free expansion due to generated heat. It must not touch hot objects or flammable materials.

The detailed requirements concerning the machine positioning in the compressor room are described in section 4.1.



Transport of the machine with a forklift.

2.2. Operating safety requirements

In addition to the requirements contained in the sections: Screw compressor operation description; Start up; Maintenance; the following rules should be observed.

- The compressor is only designed to compress air.
- All safety equipment must be in place while operating the machine.
- The factory-mounted safety equipment must not be removed. Please, remember to remove any transport brackets (if applicable) before first start-up of the compressor. The transport brackets are only used to protect the machine during transport.
- There are hot parts in the compressor e.g. conduits, air and oil coolers, screw block. They will scald when touched.
- No unauthorized modifications in the control system are allowed. After power failure, the compressor must be restarted when the power supply is recovered.
- It is prohibited to remove the green and yellow protective conductors that prevent electric shock.
- No additional equipment can be mounted on the air receiver (except for the equipment allowed for use by the manufacturer).
- No welding operations or any other repairs can be performed on the air receiver.
- The plugs and other air receiver accessories can only be removed after the air receiver depressurisation to the ambient pressure.
- General safety rules should be observed while depressurising the air receiver. Air must be vented slowly. Keep the air stream away from people.
- Do not allow oil spill around the compressor.
- It is strictly prohibited to service the safety valves or to change their settings.
- Do not change settings of the pressure switches above the value given in the identification plate or in the Operating and Maintenance Manual.
- Fulfil the obligation to register the compressor air receiver in the Office of Technical Inspection (UDT). Two sets of the required documents of the air tank (if provided) and safety valve are included with the compressor documentation. The compressor documentation is accompanied by the set of the required documentation of the air receiver (if applicable) and safety valve.
- Do not remove the temperature sensor (transmitter) or pressure transmitter.

2.3. Other hazards



The compressor installation, switching on/off and maintenance must be carried out by the qualified personnel who strictly follows the data included in the product technical documentation and safety rules to avoid any hazards. The risks that could not have been eliminated during the design stage are described in the table below.

Unit	Residual risk	Action	Precautions
water cooler, frame	minor cuts	touching	avoid touching, wear protective gloves
screw assembly, end cooler, pressure conduits	danger of scalds	touching	avoid touching, wear protective gloves
metallic parts and electric wire	electric shock	damage of wire insulation upstream the motor breaker, live metallic parts	adequate guard for the power supply lead; check the wire insulation for damages
around the compressor	danger of scalds	fire due to shorting or overheating of the power cord before the electrical box	use the cross section of the power cord and the protection corresponding to the applicable standards

2.4. Meaning of pictograms

Pictograms (safety symbols) located on and inside the compressor are described below. Explanation is provided below any of them.

For technical reasons, it is not always possible to attach the pictograms in the very vicinity of the points of risk.

		
AUTOMATIC MACHINERY MAY START	RISK OF SCALDING	RISK OF ELECTRIC SHOCK

3. Technical data

Type		KOMPBERG ZX55
Overpressure*	MPa	1,0
Max capacity	m ³ /h	397
	m ³ /min	6,61
Weight	kg	3400 kg
Dimensions (LxWxH)	mm	2500/1400/2000
Compressed air connection		G 1 1/2
Ambient temperature	°C	+5 ÷ +40 °C
Compressed air temperature	°C	+10 do 15 °C above ambient temperature
Noiselevel L**	DB(A)	85
Screw air-end type		CD8D
Nominal motor power	kW	55
Supply voltage		400V/50Hz/3ph
Nominal fan motor power	kW	4
Cooling air requirement	m ³ /h	16500
Power lead cross sectional area	mm ²	3x50+PE
Protection	A	125

*) - Capacity measured acc. to EN ISO 1217: 2006 and EN ISO 5167-2.

**) - Noise level acc. to EN ISO 2151.

- Momentary value of acoustic pressure corrected by C characteristic does not exceed 130dB.

- Equivalent acoustic pressure level corrected by A characteristic does not exceed 85 db(A).

4. Setting

4.1. Room requirements

- The compressor requires no foundations. It must be positioned on a hard and even surface. Take into consideration the floor load capacity, if the machine is installed in a building.
- Strictly observe the minimum distances from walls and other machines. When several compressors are installed, pay attention to the direction of cooling air flow; no compressor should suck air which is heated by other machine. Minimum distances from the room walls and other objects are given in the drawings below.
- Protect the room in which the compressor is installed from negative temperatures. The inlets and outlets to and from the room should be located in such a manner to protect the interior from weather conditions.
- Heat generated during compression should be extracted outside (or to other rooms), and fresh air should be supplied from the outside.
- If the gravity ventilation is insufficient (windows, openings in a wall etc.) in the compressor room, air exchange should be provided by fans. To ensure correct heat extraction, the fans should have total capacity about 15 to 20% higher than the total cooling air requirement for all compressors installed in the room. The required cooling air volume is specified in the Technical Data section.
- Ambient temperature in the room should be from + 5°C to +40°C.
- Provide sufficient room for maintenance operations.
- It is necessary to consult our specialists when you want to install a duct supplying air from the outside or use air for heating the rooms.
- The compressor room should be well lighted to ensure trouble-free and safe service of the equipment.
- To improve ventilation in the compressor room, the machine can be connected to the discharge air duct; in such case, please contact BERG.

The suitable ventilation in a room will prevent the possibility of negative pressure generation or undesired temperature increase.

When there are any problems in ensuring the suitable ventilation in a room, please contact BERG.

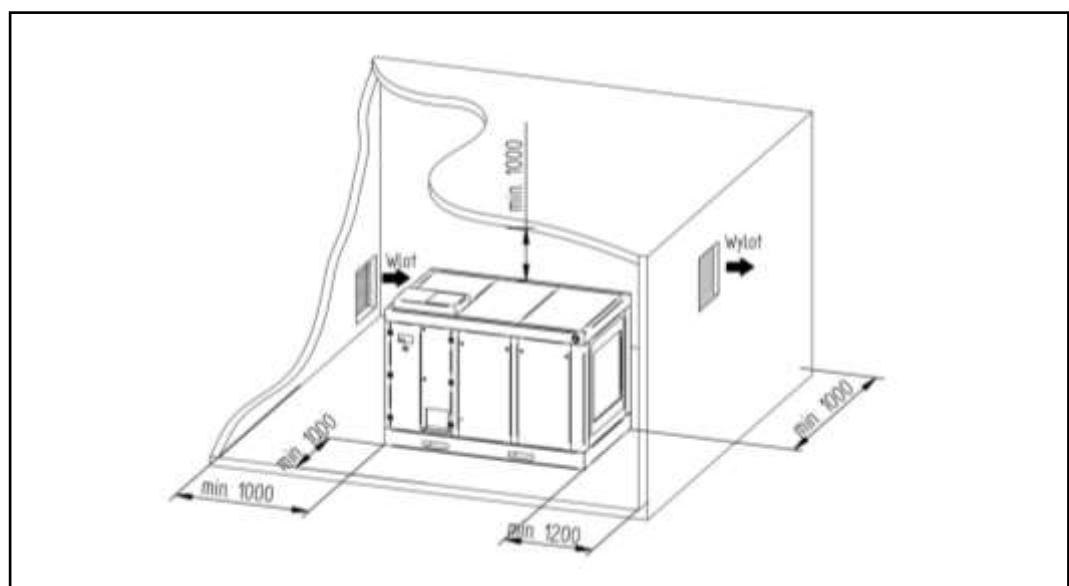

4.2. Requirements concerning electrical system

- The compressors are designed to be supplied by a four-conductor 400 V AC, 50 Hz power line.
- The compressors are equipped with PE terminal.

No.	Compressor type	Power lead cross sectional area mm ²	Fuse size NH gL/gG, 500V, 100kA D gL/gG, 500V, 50kA
1	KOMPBERG ZX55	3x50mm ² +PE	125

- The power cable cross sectional area should be matched to the current drawn by the compressor.
- The compressors can only be operated on three-phase earthed system (TN).
- The compressor must be supplied from the distribution board equipped with a slow blow fuse and circuit-breaker that enables the compressor power supply to be completely disconnected.
- Electrical connection of the compressor should be performed in accordance with the attached electrical diagram.
- Only authorised personnel or qualified electrician is allowed to perform electrical connections.
- Use the required safety measures in accordance with the suitable regulations.
- Calculate the power cable cross sectional area and fuse sizes according to the local regulations and operating conditions.
- Below there are presented the recommended power cable cross sectional areas and fuse sizes for standard compressors.
- A user takes a full responsibility for selection of an electrical system and power supply connection for the compressor.

Recommended power cable cross sectional area and fuse sizes

4.3. Compressed air connection



It is recommended to use galvanized steel or plastic tubes for the compressed air system.

When the compressed air treatment equipment (filters, dryer) is installed, the existing compressed air piping should be replaced with a new one, unless air supplied previously was treated by similar equipment.

Each BERG compressor should be connected to the compressed air network by using a flexible conduit or flexible connector (axial expansion joint) and shut-off valve.

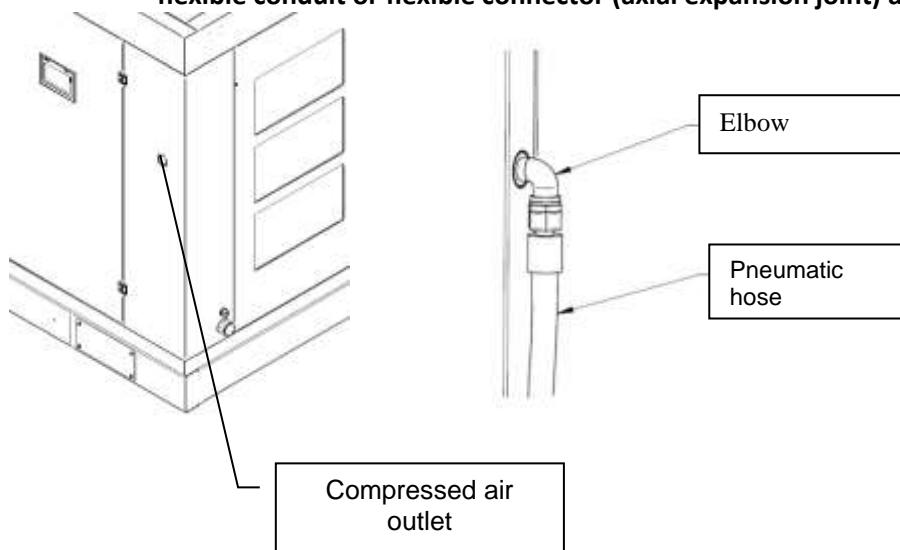

5. Screw compressor operating description

5.1. Screw compressor KOMPBERG ZX55 – operating description

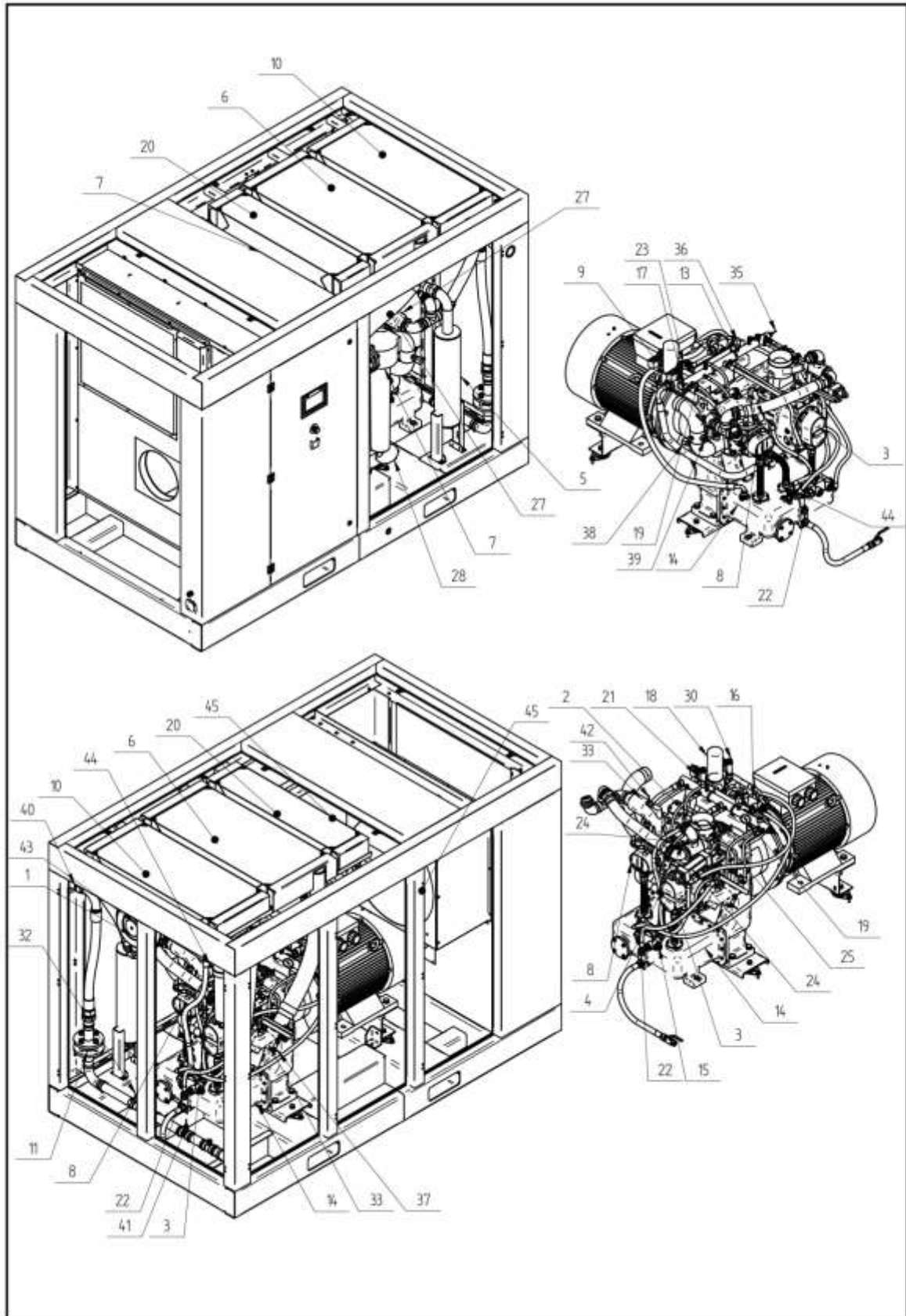

800-1332-000

General view of an oil-free screw compressor KOMPBERG ZX55

The compressor is equipped with two stage air end ("of dry-type") without oil injection into the compression chamber with the bearings and gearing and the coat of the high pressure part are lubricated and cooled with oil.

POWER AND CONTROL

The compressor (screw air-end) is driven by an electric motor through a flexible coupling. Control of the entire electrical system is placed in a electrical box.

AIR CIRCULATION

The air is sucked through the air filter (1) and the suction controller (2) to the first stage (3). The compressor suction regulator is equipped with a second stage discharge (4) terminated by a noise damper (5). After compression to the overpressure of 0,35 MPa the air is forced from the 1st stage to the intercooler (air-water exchanger) (6). After cooling in the cooler, the air flows through the condensate separator (7) and is sucked to the second stage (8). I-stage compression and internal system are protected against pressure rise above the permissible value by a safety valve (9). After compression, it reaches an overpressure of up to 1,0 MPa and is forced into the end cooler (air-water exchanger) (10), and then through the check valve (11) to the compressor outlet.

OIL CIRCUM

The oil is sucked by the pump (13) from the compressor reservoir (13) and is forced to the overflow valve (16) in which the oil overpressure is limited to 0.25-0.30 MPa and then flows to the oil filter assembly (18). The oil filter set is fitted with a thermostat (17) which, depending on the oil temperature, directs the oil directly through the oil filter (18) to the manifold (19) or at temperature exceeding 55 ° C to the oil cooler (20) and then through oil filter (18) to the manifold (19). The pressure in the manifold is limited to 0.14-0.16 MPa with an overflow valve (15). The outlets from the oil filter assembly to the oil cooler and inlet from the radiator to the unit are equipped with electromagnetic shut off valves (21) and (30) which are closed (normally closed NZ) when in the de-energized condition. These valves are designed to prevent the flow of oil from the radiator to the installation and further to the oil tank, which avoids the need to always fill the radiator with oil after the compressor's standstill. In addition, the oil level display in the sight glass (22) is always reliable (without shut off valves the sight glass would be completely filled with oil).

From the manifold the oil is distributed to both compression stages ie bearings, seals and coats of I-stage and II- stage. After passing through the compressor, the oil flows to its reservoir (14). After the filter, the oil is also fed to the three-way valve (23) and, depending on the compressor load, flows to the hydraulic cylinder (24) controlling the shutter (25) in the suction controller (3). In the second position, the oil from the valve (23) flows to the compressor reservoir (14). Also the oil from the hydraulic cylinder is directed to the compressor tank.

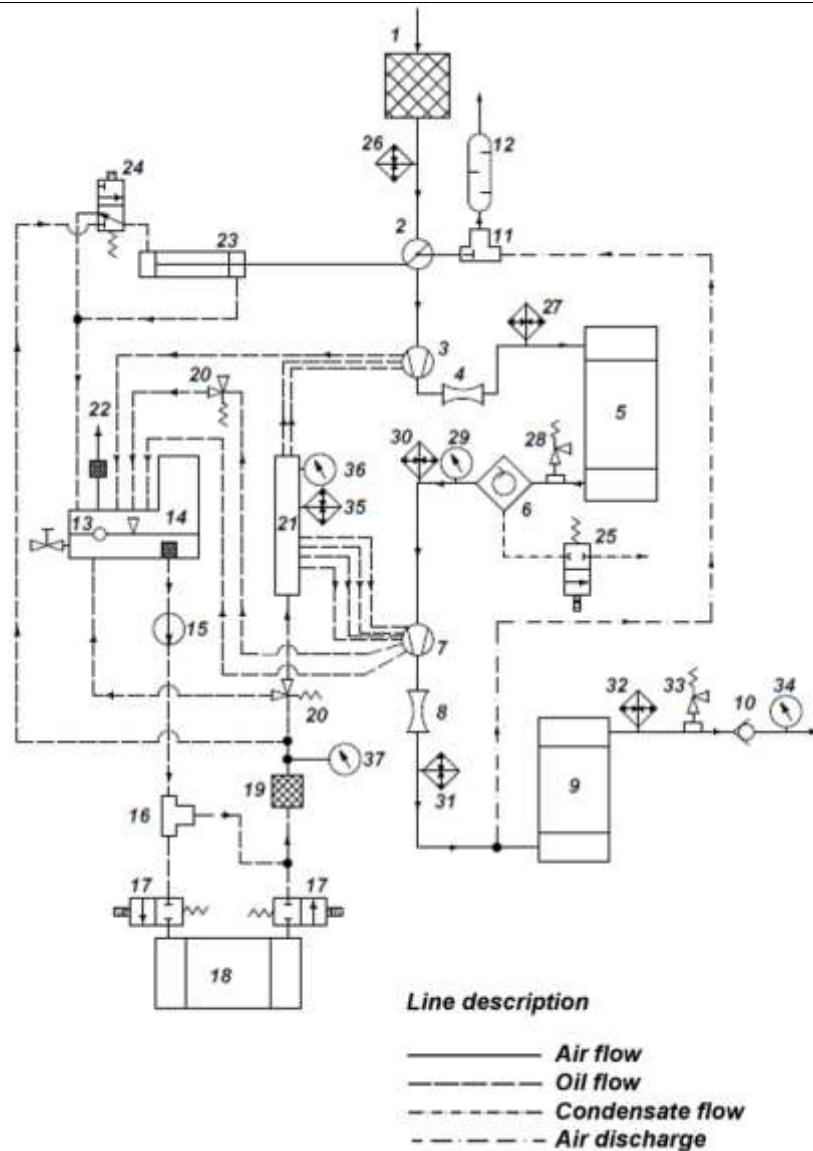

Technological diagram

1	Air filter	19	Oil filter
2	Suction valve	20	Overflow valve
3	First stage	21	Oil distributor
4	Venturi nozzle	22	Vent filter
5	First stage cooler	23	Hydraulic cylinder
6	Cyclone separator	24	Solenoid valve
7	2nd stage	25	Solenoid valve with time system
8	Venturi nozzle	26	Air filter pollution sensor
9	2nd stage cooler	27	Temperature sensor
10	Check valve	28	Safety valve
11	2nd stage unloading	29	Pressure sensor
12	Silencer	30	Temperature sensor
13	Oil sight glass	31	Temperature sensor
14	Oil tank	32	Temperature sensor
15	Oil pump	33	Safety valve
16	Thermostatic valve	34	Pressure sensor
17	Solenoid valve	35	Temperature sensor
18	Oil cooler	36	Pressure sensor
		37	Manometer

MEASURING SENSORS

The following temperature sensors and pressure transducer are installed in the compressor installation:

- (39) - air filter pollution sensor,
- (33) - temperature sensor - realizes the measurement of the compressed air temperature after the I stage (3),
- (35) - temperature sensor - realizes the measurement of the compressed air temperature after cooling in the radiator (6),
- (34) - pressure transducer - performs measurement of air pressure after the radiator (6),
- (38) - temperature sensor - realizes air temperature measurement after the II stage (8),
- (37) - temperature sensor - realizes air temperature measurement after the radiator (10),
- (36) - pressure transducer - performs the measurement of compressed air pressure after the cooler, behind the check valve,
- (31) - temperature sensor - performs measurement of oil temperature,
- (32) - pressure transducer - performs oil pressure measurement.

These sensors and transducers work with the PLC.

WATER CONDENSATE DRAIN

Water in the compressor air system means a very high risk of failure, including the screw air end failure. This is why the water condensate from the air is carefully drained in the compressor. The condensate from the separator (7) after the intercooler (6) is drained out of the compressor by float operated mechanical condensate drain (25).

VENTILATION OF THE SCREW AIR-END INSIDE

During operation of the compressor in the spaces in the interior of its bodies, bearing housings and seals a small overpressure is produced. This is detrimental to the correctness of the lubrication and sealing processes. Therefore, these spaces must be ventilated. This is accomplished by means of a flexible hose and an air filter located at the tunnel of the fan; In the figure it is marked with a symbol (40).

COMPRESSOR COOLING

The compressor is cooled in a forced manner by means of a fan with its own electric drive. The air is sucked in through the inlets on the front and rear wall of the housing and pushed through a set of radiators placed on top of the compressor and thrown outside the compressor.

OPERATION OF THE OIL FREE COMPRESSOR

The compressor is started by pressing the START button on the control panel. After the button is pressed, the compressor drive is activated. The compressor is designed for intermittent run. The intermittent operation involves air pressurisation until the maximum overpressure set on the pressure switch is reached.

When this pressure is reached, the compressor switches to idle running (the hydraulic actuator closes the air supply on the compressor suction side) and then there is a countdown of the time to stop. If during this time the air pressure decreases, the compressor will start again, and if not, it will shut down after the countdown. The compressor is restarted when the overpressure in the piping drops to the minimum value set in the controller.

The compressor can be stopped at any time by pressing the STOP button on the controller panel. The operation is resumed by pressing the START button.

When the overpressure in the piping on the compressor start exceeds the value set in the pressure switch, the compressor will start only after the overpressure drops to the minimum value.

After stopping the compressor with the EMERGENCY STOP (STOP AWARYJNY) button and after the supply voltage is switched off and on, the compressor can be started by unlatching the EMERGENCY STOP (STOP AWARYJNY) button and pressing the START button. The compressor is provided with an additional protective function which prevents machine start when any of parameters given in Tab.[Technical data] is exceeded.

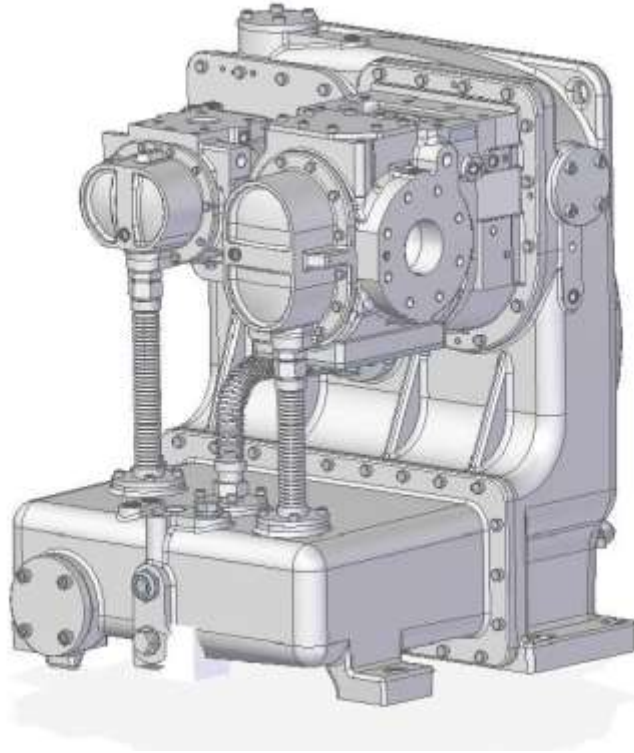

Screw air end CD8D

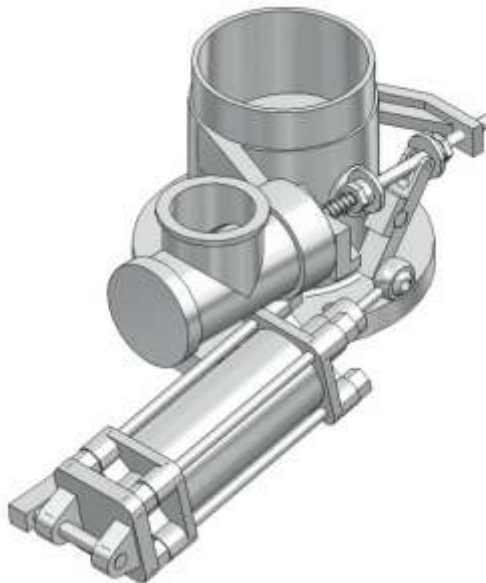

Suction regulator

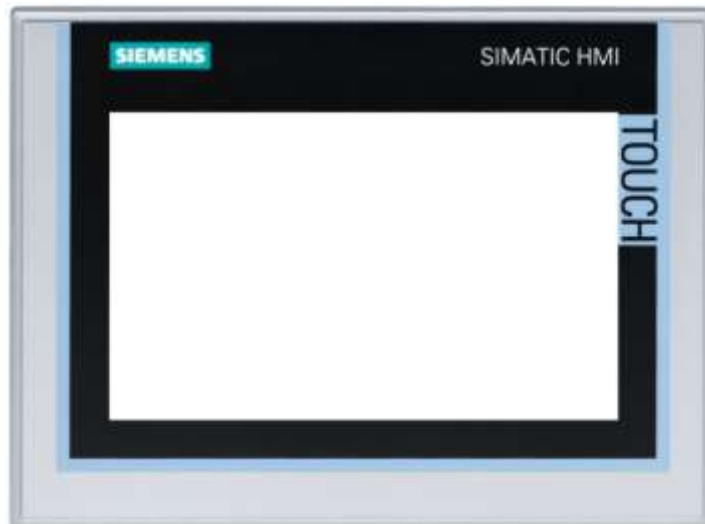

Operating panel



Controller instruction is an integral part of the OMM of compressor KOMPBERG ZX55

6. Start-up

6.1. Start-up preparation

Each compressor unit is tested in the factory and carefully inspected to ensure proper machine performance and meeting the specifications declared.

Strictly obey the following rules before starting the machine for the first time:

- Get thoroughly familiar with the compressor Operating and Maintenance Manual and the Warranty Book.
 - Check the power cables for possible damage, short-circuits and electrical breakdowns. Only authorised / qualified electrician can perform work on electrical equipment and components.
 - Make sure the power supply voltage is correct and the required protections are in place; do not connect the compressor to a power source of different voltage than that specified in the Operating and Maintenance Manual.
 - Connect the phase conductors so that the **rotation direction is as indicated on the screw assemble**.
 - Check the oil level in the screw block, top it up, if necessary.
 - Connect the compressor to the compressed air system with a flexible conduit.
 - A compressed air receiver tank is necessary for proper compressor operation (min. 2500l).
 - When the compressed air receiver tank is located outside the compressor room, install the pressure gauge, connected to the tank or pressure conduit supplying the tank, in a visible location.
 - Do not operate the compressor above the maximum operating pressure that is given on the identification plate. It is not recommended to operate the compressor at the delivery pressure below 0.5 MPa. Please contact our technicians when it is necessary to set that overpressure.
-

- Check if all doors/covers are closed.
- Open the valve that shuts off the compressor from compressed air system.
- Check the "EMERGENCY STOP" button position.
- Switch on the compressor power supply.

When the compressor and compressed air system condition is checked, you can proceed with starting the compressor.

To start the compressor, press the "START" button on the control panel. The compressor motor starts working and depending on the overpressure in the compressed air system, the machine switches to the loaded operation mode or, if the overpressure in the compressed air system is higher than the minimum start pressure, it switches to the stand-by mode and starts again after its drop.



Incorrect rotation direction of the screw block rotors for more than 5 seconds will damage the screw compressor.

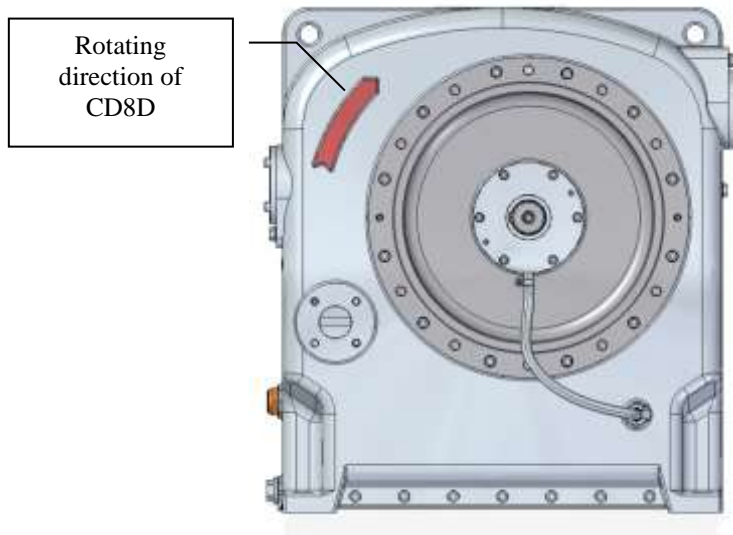

Proper direction of screw air end rotation

6.2. Restart (after longer downtime)

Follow the procedure described below to start the compressor which has been out of use or stored for over 3 months:

Check if there is no water in the screw assembly.

Turn the compressor shaft several times by hand in the rotating direction.

check oil level in the screw assembly body, top it up if necessary,

Perform the trial run of the compressor screw block lasting for at least 15 minutes.

During the trial run, check the machine for correct operation, noise, vibration, oil leaks and tightness of connections in the compressed air system.

7. Maintenance

7.1 General requirements

To ensure proper functioning, the compressor must undergo maintenance procedures. The following general requirements must be met while performing the maintenance:

- Place the warning sign as shown below in a visible location, while the maintenance work is in progress:

WARNING
MACHINE UNDER REPAIR

- All maintenance work should be performed by authorised and trained personnel. Contact the factory service in case of technical problems.
- Before any maintenance work is started on the compressor, disconnect it from power supply and protect from unauthorized and accidental starting.
- Check if the supply voltage is lacking.
- Any maintenance and repair work can only be carried out when the compressed air system is completely unloaded i.e. air pressure in the system is reduced to ambient pressure.
- Before restarting the machine, make sure that there is nobody working on the compressor and there are no people in the vicinity.
- Use appropriate tools for maintenance and repair work.
- Use only original spare parts.
- For cleaning purposes never use flammable or corrosive solvents that could damage the machine components. Take appropriate safety measures against toxic vapours from cleaning agents. Biodegradable detergents should be used.
- The workplace must be kept absolutely clean when maintenance work is carried out. Do not allow any parts to get contaminated. Parts and exposed holes should be covered with a clean cloth, paper or adhesive tape.
- Upon finishing the maintenance work, make sure no tools or other objects are left on or inside the compressor.
- Before restarting the machine after maintenance, check operating pressures, temperatures, time settings, and test the switching and control equipment for proper functioning.
- Protect the motor, air filters, electric components, control equipment etc. from penetration of moisture.
- Do not perform any welding or any other works generating heat close to the oil system.
- Under no circumstances should the noise absorbing material be removed or relocated.

The manufacturer accepts no responsibility for any damage and personal injuries resulting from failure to observe the present safety rules or from carelessness during operation, work and maintenance, even in circumstances not expressly mentioned in this Operating and Maintenance Manual.

In order to ensure fault-free operation of the compressor, observe the following instructions relating to periodic inspections and maintenance operations.

7.2. Maintenance and checks

7.2.1 Maintenance at the beginning of compressor use, after oil and drive belts (if present) change

Maintenance interval	Operation
after 2 work hours	- check oil level in the receiver, top it up if necessary,
after 2 work days	- check oil level in the receiver, top it up if necessary,
after 1 week of work	- check oil level in the receiver, top it up if necessary,

7.2.2 Daily maintenance

- visually inspect the state of pneumatic and oil conduit connections,
- check the air overpressure gauge and temperature indicator for correct readings,
- check the compressor performance for unusual symptoms, such as excessive noise and vibration,
- check oil level,

7.2.3 Periodic maintenance

Every 1000 work hours:

- check the air filter for contamination and replace if necessary (in case of higher air dustiness, more frequent cleaning and changing of the filter is recommended),
- check the condition of the elastic coupling,
- clean the air and oil cooler ribs if necessary.

7.2.4 Warranty and post-warranty checks

every 2000 work hours or after 1 year	<ul style="list-style-type: none"> - change the filter mat at the cooling air inlet, - change the air filter cartridge, - check electric clamp terminals, fasten if necessary, - clean the air and oil cooler ribs, - test the non-return valve for proper functioning, - check the condition of elastic coupling, - check the tubing for leaks, mend if any, - test the pressure switch for proper functioning, - check the oil temperature indicator, - check the condition of safety valve, - check the motor thermal protection setting.
every 8000 work hours or after 1 year	<p>In addition to the activities required after 2000 work hours:</p> <ul style="list-style-type: none"> - change the filter mat at the cooling air inlet, - change the air filter cartridge, - change oil filter, - change oil, - inspect the electric system and check it for proper functioning.



During the warranty period, the checks must be performed only by one of the servicing companies listed in the Warranty Book

7.3. Basic components requiring maintenance. Maintenance operations.

7.3.1. Air filter cartridge

The filter cartridge can't be soaked in oil or other liquids.

Change the filter cartridge every 2000 work hours or once a year. In case of highly contaminated ambient air, the cartridge must be cleaned or replaced more frequently.

Maintenance procedure:

- Stop the compressor and close the pressure conduit valve. Reduce the overpressure in the screw assembly body to reach the atmospheric pressure (see the microprocessor controller).
- Safeguard the compressor from restarting by an unauthorized person, e.g. by cutting power supply off.
- Open the filter cover and carefully remove the dust.
- Take the cartridge out, clean it or replace with a new one.
 - Rinsing: do not apply force, avoid damaging the cartridge. Clean contact surfaces of gaskets.
 - Purging: purge the external surface of the cartridge with dry compressed air, at the pressure up to 0.5 MPa, askew from the inside and outside.
- Replace the filter cover taking care to position it properly.
- Start the compressor and check for correct operation.



No particles of dirt or dust should get from the suction side into the screw stage.

7.3.2 Cleaning or replacing the filter mats.

Filter mat is placed at the inlet into the housing. If the filter mat get dirty, cooling of the compressor may be insufficient.

Maintenance operations:

- Carefully, without tools, remove the filter mat from the housing.
- Thoroughly vacuum or flick the mat. In case of heavy dirtiness, the mat can be washed in water with detergent.
- If it's impossible to clean the mat or the mat is damaged, it should be completely replaced.
- Carefully placed the filter mat in the housing.

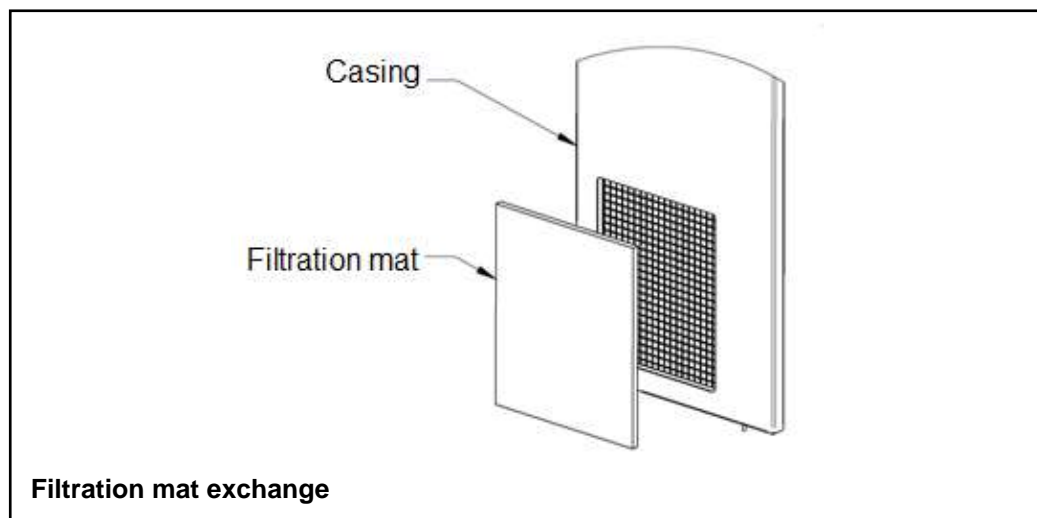

7.3.3. Oil filter

Change the oil filter every 8000 hours or once a year.

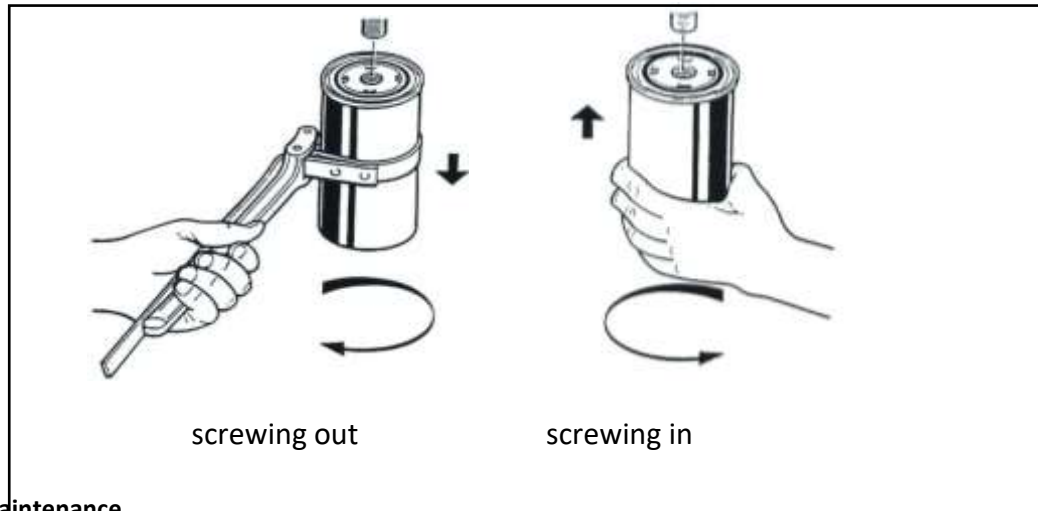

Oil filter - maintenance

Maintenance procedure:

- Stop the compressor and close the pressure conduit valve. Reduce the overpressure in the screw assembly body and oil system to reach the atmospheric pressure (see the oil pressure manometer / microprocessor controller).
- Safeguard the compressor from restarting by an unauthorized person, e.g. by cutting power supply off.
- It is advised to use a special spanner to replace the filter. Caution – hot oil!
- Rub some oil onto the gasket of the new filter before screwing it in. Fill the new filter, held vertically, with the same type of oil as that in the separator tank. Then screw the filter in by hand, without using any tool.
- Start the compressor and check for leaks.

7.3.4. Oil level

Sufficient oil level in the oil receiver is of critical importance for trouble-free performance of the compressor.

Oil check intervals:

- after prolonged compressor off-time,
- every 100 hours.

Procedure:

- check oil level after 1 minute from the compressor stop,
- the oil should be above the middle line of the sight glass (during normal use when the cooler is full of oil at all times).

Oil level indicator

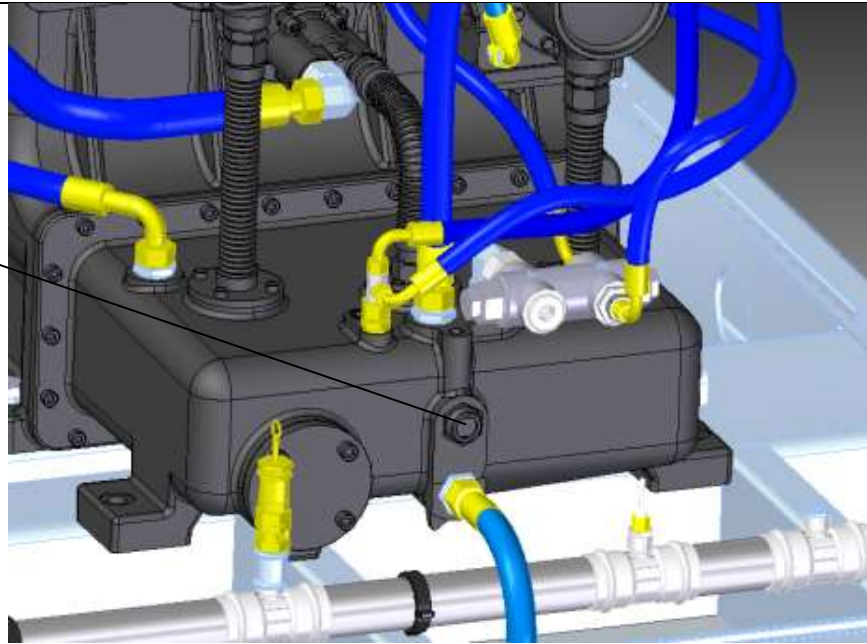

7.3.5 Changing oil

The oil can be changed only when the compressor is stopped and completely depressurised. The machine should be heated up to the operating temperature (oil temperature between 50 and 60°C).

Maintenance procedure:

- Stop the compressor and wait until the overpressure in the screw assembly body and oil system reaches the atmospheric pressure (look at the microprocessor controller).
- Safeguard the compressor from restarting by an unauthorized person, e.g. by cutting power supply off.
- Start the options for manually opening of the oil control solenoid valves in the radiator (see the controller operating instructions).
- Unscrew the compressor crankcase ventilation hose on the compressor stage body (see Fig. 11).
- Place a suitable container and carefully unscrew the oil drain plug located under the oil reservoir on the hose.
- Drain the oil from the stage body completely and screw in the drain plug again.
- Pour new oil through the filler neck to the max.level Close the bleeder hose.
- Switch on the screw compressor and leave it working for approx. three minutes (the oil cooler should be completely full).
- Check the oil level: top up with the missing amount of oil up to max.
- Used oil should be disposed of in accordance with applicable regulations.

Oil dedicated for oil free screw compressors has been used.

oil cap

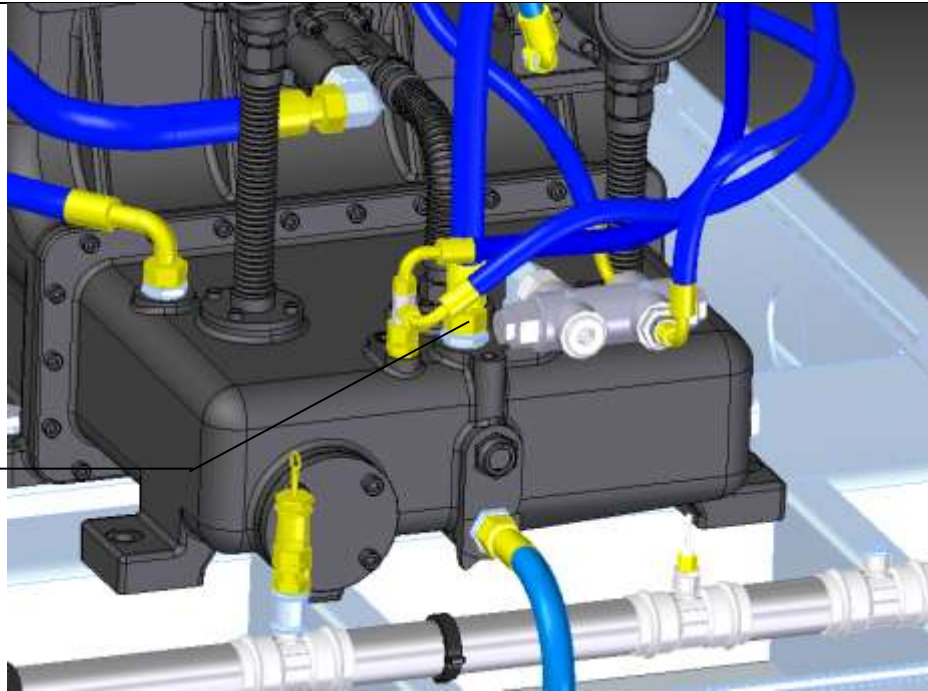

For compressor lubrication is suitable hydraulic oil HLP according to DIN 51515 or turbine lubricant according to DIN 51524 Part 2. The oil should have the following parameters:

Kinematic viscosityacc. ISO	VG 46
Kinematic viscosity at 40°C	41,4-50,6

Oil of the specified parameters is the only acceptable oil for use in BERG oil-free screw compressors (oil - part No. COL0069 ie.package of 10 L).

7.3.6. Handling wastes produced while operating the compressor

The condensate (condensed water from the compressor, tank or compressed air purification equipment) may not be drained directly to sewer. It should be disposed of according to the valid legislation on handling wastes; waste code 12 01 09.

Used oil should be disposed of according to the valid legislation on handling wastes; waste code 13 02 05.

Oil filters and oil filter cartridges should be disposed of according to the valid legislation on handling wastes; waste code 16 01 07.

7.3.7 Oil cooler (exchanger) / interstage / final air

The safety of the screw compressor requires regular radiator cleaning. The cooling ribs of the radiator should be kept clean. Only in this way is full cooling possible. Sufficient cooling means lower oil temperature and thus longer durability. It is advisable to clean the radiator fins with compressed air, a steam jet or a detergent solution. If this method of cleaning does not cause a decrease in the working temperature, the elements of the radiator through which the oil flows should be cleaned inside from the carbon deposit (nagar) using available means for removing carbon deposits (nagar). To do this, the radiator should be removed. In case of strong contamination of the intake air (cooling air) it is necessary to more frequently clean the radiator, especially when the temperature at the compressor outlet is more than approx. 10 to 15°C above ambient temperature.

Maintenance procedure:

- Stop the compressor, close the pressure conduit valve.
- Lower the overpressure in the screw assembly body till reaches the atmospheric pressure (to lower the overpressure inside the screw assembly body wait about 5 minutes after switching off the compressor,
- Safeguard the compressor from restarting by an unauthorized person, e.g. by cutting power supply off.
- Dismantle the radiator.
- Clean and remove impurities.
- Reassemble all disassembled components.
- Fill (top up) the compressor with oil.
- Carry out a operating test for approx. 3 to 5 minutes.
- Stop the compressor, check the oil level and top up if necessary.

7.3.8. . Electric motor

When the compressor is running, check the motor operation by paying attention to the following:

- Operating noise,
- Excessive vibration,
- Excessive current consumption – protection activation in the electrical cabinet,
- The condition of the fixing screws,
- A degree of fouling.

The motor (compressor) should be stopped immediately in case of:

- Overheating,
- Smoke or burningsmell,
- Excessive vibration,
- Bearing noise.



The machine can be restarted after removing the cause of any failures.

Periodic motor inspections:

The motor inspection should be performed at least once per 2 years.

The inspection should be performed by the in-house personnel or properly qualified personnel from specialized companies.

Any repairs or special inspections should be performed by the specialised workshop or the manufacturer service.

Replacement or lubrication of the motor bearings must be performed in accordance with the manufacturer's recommendations. The permissible hours of the bearing operation to the replacement or lubrication are presented in the table below. When any symptoms indicating the bearing damage occur (unusual noise or increased temperatures), contact the service immediately.

Hours of operation until the performance of service operations			
Motor power	Bearing type	Hours of operation	Operations
3-22 kW	Maintenance-free	40000 h	Replacement
30-55 kW	Maintenance-free	20000 h	Replacement
75-90 kW	Requiring maintenance	4000 h	Lubrication
110-200 kW	Requiring maintenance	3000 h	Lubrication

7.3.9 Safety valve

The safety valves fulfil an important function in pressure equipment and systems. They require particularly careful and professional service. Any operational shortcomings may damage the

valve mechanism, and consequently damage the entire pressure unit. Therefore, during the equipment operation particular attention should be paid to the following:

- Correct setting of the safety valve, appropriate to the operating parameters of the equipment being protected,
- Appropriate protection of the valve mechanism against unauthorized adjustment and a risk of damage. The valve seal must be intact,
- Periodic inspections of the valve for correct operation according to the requirements of the office of technical inspection regulations.

The safety valve operation inspection involves blowing the valve by pulling the handle (wheel) upwards. The pin, lifted by pulling the wheel up, releases the pressure of the valve spring and moves the head a little up and allows the compressed air to flow through the valve.

The handle can be loosened at the pressure equal at least 50% of the operating pressure.

The valves delivered require no special maintenance. They should only be periodically (every 1000 hours) blown by pulling the handle of the push pin. Special care must be taken while performing this operation. Keep away from the stream of air blown out (caution – the air may be hot!).

In case of the valve leaks, contact the manufacturer service to arrange its repair. The valve cannot be repaired by the user itself.

Blocking the pin, tightening the adjustment nut or covering the valve outlets is not allowed.

In addition to the guidelines and requirements listed in this paragraph, the user is obliged to observe the regulations being in force in the country in which the equipment is operated.



The safety valves are intended only for protection of: pressure tanks, conduits for compressed air or other neutral gases, sources of compressed air from overpressure (above the limit for that type of equipment).

The safety valves may not be used as relief valves for pressure adjustment.

8. Troubleshooting

Symptom	Cause	Remedy
the compressor will not start	power failure	check for supply voltage in the power supply terminals
	activation of main protection activation of motor protection	check the protection, replace or switch on
	temperature indicator or temperature transducer fault	check, replace if damaged
	temperature indicator (microprocessor controller) activated because the temperature was too high	check: <ul style="list-style-type: none"> - oil level and top it up if necessary, - cooling: remove causes of insufficient cooling, - thermostat: if faulty, replace the entire thermostat or its cartridge.
	ambient temperature too low	heat the room up to reach at least +5°C
difficult compressor start	supply voltage too low	check supply voltage, bring it to correct value
	ambient temperature too low	heat the room up to reach at least +5°C
	non return valve fault	call the service
wrong rotation direction	wrong phase sequence	swap two phase leads in the compressor terminal block or in the electric cabinet
oil temperature too high, the compressor does not start	ambient temperature > 40°C	ensure adequate ventilation in the room.
	contaminated cooler	clean the cooler (exchanger)
	operating pressure above the set value	adjust the pressure switch or enter correct settings in the controller
	oil level too low	top oil up as required
	oil thermostat malfunction	replace the entire thermostat or its cartridge
	lack of cooling water	provide water to compressor
	damaged temperature transducer	replace with a new one
	other causes	call service
forcing pressure too low	wrong pressure switch or microprocessor controller setting	adjust the pressure switch or enter correct settings in the controller
	insufficient compressor capacity in relation to air requirement	install additional source of compressed air
	leak in the system	check the tubing for leaks, remove leaks if any
	air filter contaminated	change air filter cartridge (during the warranty period to be replaced obligatorily by the service staff only)
	damaged pressure transducer	replace with a new one
	damaged suction regulator	call the service staff
activation of motor protection	ambient temperature too high	improve room ventilation



	failure of one phase in motor power supply	check motor leads, contactor and protection
	supply voltage too low	ensure correct supply voltage
	discharge pressure higher than specified on the nameplate	adjust the correct settings in the controller
	screw seizure	call service
activation of safety valve	safety valve damaged	replace with a new one (with appropriate setting) or call service
	wrong microprocessor controller setting	adjust the correct settings in the controller
	damaged pressure transducer	call the service staff
	damaged suction regulator	call the service staff

Skryzka elektryczna, sterownik
 Elektroschrank, Microprozessorsteuerung
 Electrical box, controller
 Электрический ящик, Командоконтроллер

Wylot skroplin G3/4
 Kondensatablass
 Drain outlet
 Выпуск конденсата

Wylot sprężonego powietrza G2
 Druckluftauslass
 Compressed air outlet
 Выпуск сжатого воздуха

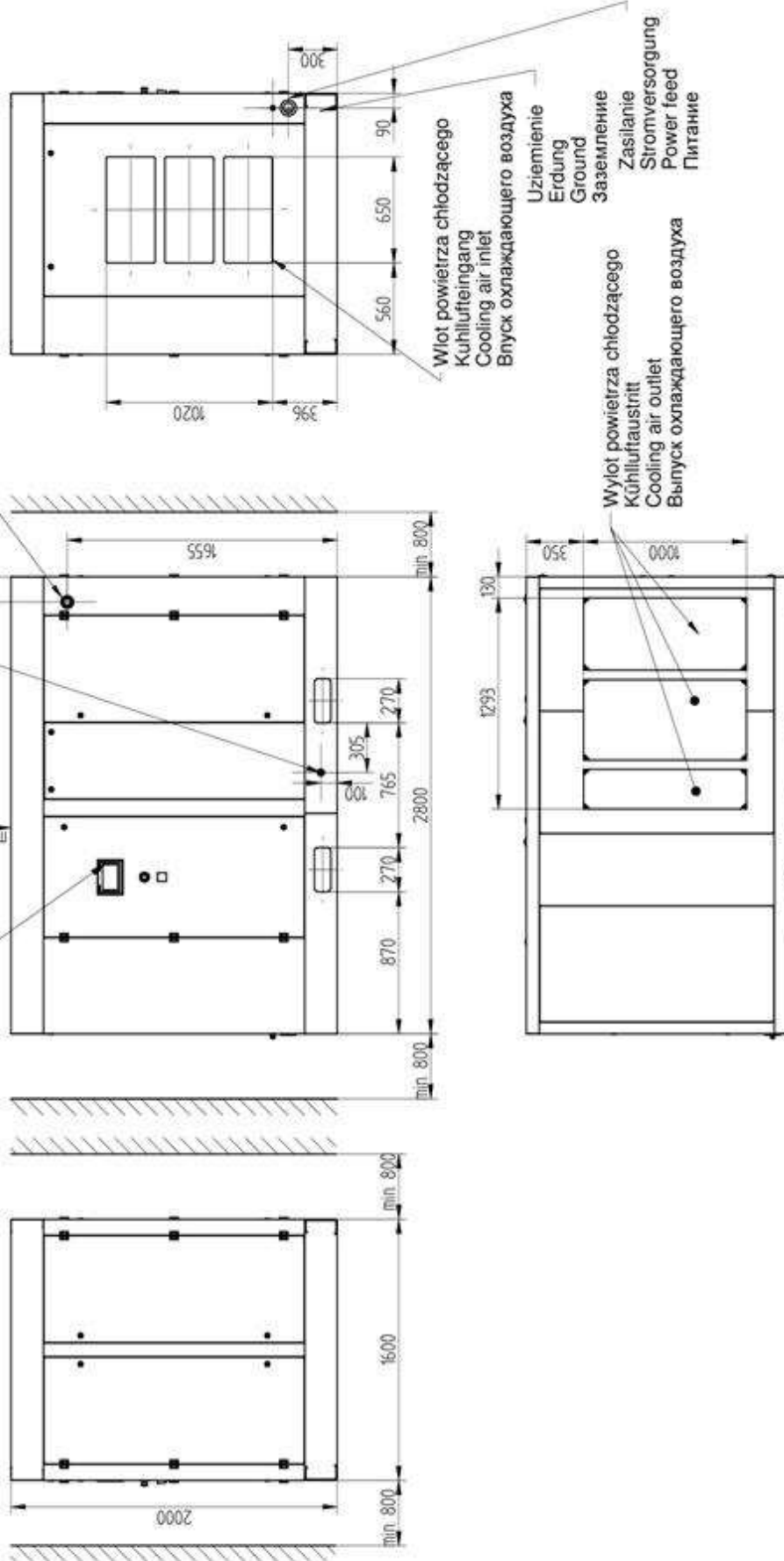

9. Consumables for one year guarantee

No.	Name	Part number	Quantity
1.	Air filter	BL 480045 + BL 480046	1
2.	Compressed air filter cartridge	Element for F 24 GW (24 G)	1
3.	Oil filter	BÖ 480001	1
4.	Coupling insert	BS 480165	1
5.	Oil	Öl 480069*	40
6.	Thermostat cartridge	BS 488580	1

* package of 10 L

10. Electrical scheme
