

DRYBERG® AD150-1200 CT

Operating manual Adsorption Dryers

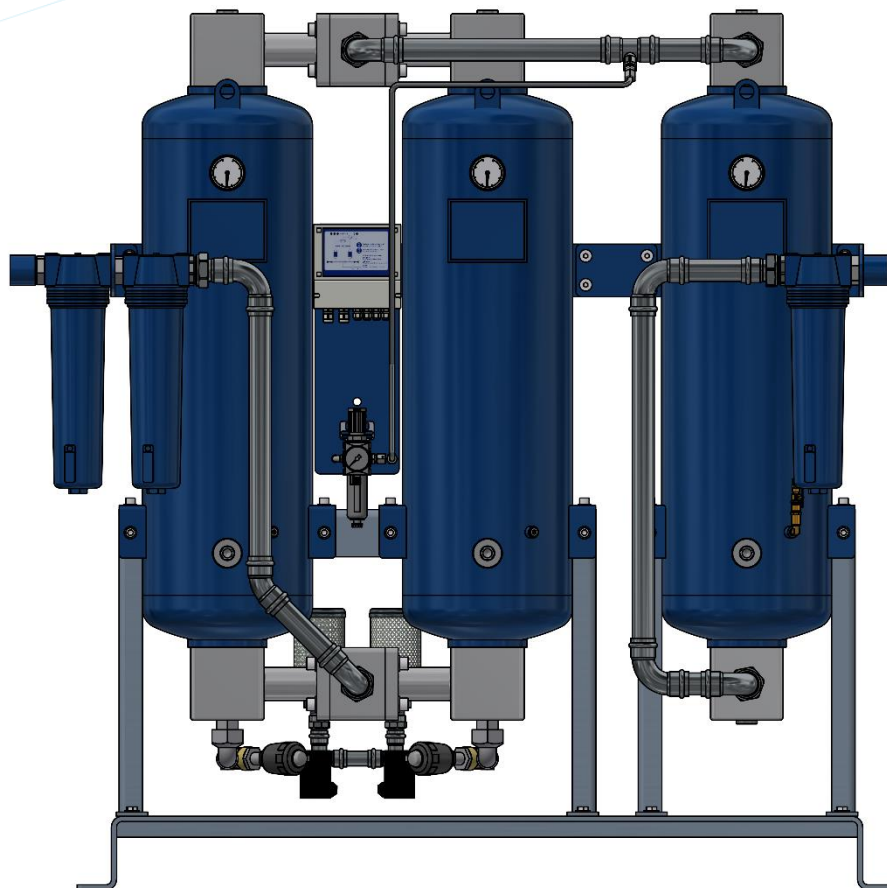

Stand: 01/2022

Contents

Contents.....	2
1. General information	4
1.1 System data.....	4
1.2 Contact data.....	4
1.3 Accompanying documents	5
1.4 Warranty notes	5
1.5 Operating manual	5
1.6 Signs and symbols used.....	6
2. Intended purpose / use.....	7
2.1 Intended use	7
2.2 Performance data.....	9
3. Safety notes.....	10
3.1 Signs and symbols	10
3.2 Danger zones	11
4. Technical product data	12
4.1 Equipment overview, front view	12
4.2 Equipment overview, rear view.....	13
4.3 Function description.....	13
5. Monitoring the operation.....	15
6. Transport, storage and setup	16
6.1 Transport.....	16
6.2 Storage.....	16
6.3 Setup.....	17
7. Installation	17
7.1 Recommendations for installation	17
7.2 Demands on the installation	18
7.3 Elimination of hazards	19
8. Commissioning.....	19
8.1 Commissioning prerequisite.....	19
8.2 Pressurisation	20
8.3 Mains operation.....	20
8.4 Disconnecting from the mains	21
9. Maintenance	21
9.1 Regular maintenance work.....	22
9.2 Daily checks.....	22
9.3 Checking the pressure dewpoint and the residual oil content.....	23
9.4 Overview of maintenance parts.....	27

9.4.1 Annual maintenance	27
9.4.2 Two-year maintenance	28
9.5 Replacing the filter elements.....	29
9.6 Replacing the desiccant	30
9.7 Replacing the pistons and cylinder liners	33
9.8 Replacing the solenoid valves	34
9.9 Replacing the silencers	35
10. Replacing the pressure dewpoint sensor	36
11. Faults.....	37
12. EU Declaration of conformity	40

1. General information

Please complete the following information according to the type plate, vessel plate and contract documents. This enables the manufacturer to clearly identify the dryer and makes it easier to give advice if there are queries. It also simplifies the provision of spare parts and support. This may correspond to separate pieces of equipment for the individual devices.

1.1 System data

Model: _____

Order No.: _____

Vessel No.: _____

Serial number: _____

Year of manufacture: _____

Date of commissioning: _____

1.2 Contact data

Manufacturer of this unit is the company:

BERG Kompressoren GmbH
Medienstraße 35,

47807 Krefeld, Germany

Internet: www.berg-kompressoren.de

1.3 Accompanying documents

Applicable documents which are not included with this documentation:

- Container documents
- Installation drawing
- Documentation for additional equipment parts
- Controller documentation
- Calibration certificate (if dewpoint controller is installed)

1.4 Warranty notes

For the conditions necessary for compliance with the warranty, please refer to our "General Terms of Sale and Delivery"

The warranty shall be void if:

- The adsorption dryer is used for anything other than its intended use.
- The instructions in this operating manual are not observed.
- External influences (e.g. aggressive substances) cause damage to the adsorption dryer.
- Maintenance intervals are not adhered to.
- Damage is caused due to incorrect or defective maintenance.
- The adsorption dryer is operated although defects are evident.
- An unfavourable or incorrect installation is selected.
- The necessary process conditions are not stipulated by the system concept (e.g. highly undersaturated compressed air at the inlet).

1.5 Operating manual

This operating manual will help clarify any outstanding questions concerning the setup, installation, operation, maintenance, repair and disposal of the dryer. It contains useful tips and advice.

It is not only written for the operator who is responsible for monitoring the daily operation of the device, but also for the service personnel who performs the installation and service. Maintenance and repair work may only be carried out by qualified personnel!

This operating manual must be read before any installation and maintenance work is started. All safety instructions must be observed!

The operating manual must be kept in the vicinity of the dryer.

As already mentioned in the warranty notes, the manufacturer accepts no liability for damages resulting from disregard of the operating manual.

1.6 Signs and symbols used

The following symbols are listed in this manual and /or are affixed to the adsorption dryer:



Tip

This symbol indicates tips for the efficient use of the adsorption dryer!



Note

This symbol indicates instructions for the safe handling of the adsorption dryer.



Caution / Warning

This symbol indicates general hazards or dangerous situations.



Danger! Compressed air

This symbol warns of dangers due to compressed air.



Danger! High voltage

This symbol warns of dangers due to electric voltage.



Slip hazard

This symbol warns of the risk of slipping.



Wear ear protectors



Wear respiratory protection



Wear goggles

These three symbols point out the necessity to wear personal protective equipment.

2. Intended purpose / use

The adsorption dryer is designed for removing compressed air by adsorption in industrial compressed air systems. It requires the supply of saturated compressed air from a supply source.

The main task is to reduce vaporous water components in the compressed air. Upstream filters and dryers ensure that only particles and drop shapes are separated. With the combined Oil vapour adsorber the oil in the compressed air is reduced.

The desiccant which is specifically designed for this purpose is used to store the water vapour molecules from the compressed air in the open pores of the adsorbent, thereby reducing the moisture content of the compressed air.

2.1 Intended use

The adsorption dryer is exclusively designed for drying compressed air! If the adsorption dryer is to be used with other gases, this must be agreed with the manufacturer. Other safety guidelines may apply here!

The adsorption dryer must be set up at a site indoors:



- which is suitable for the weight,
- weatherproof (exposure to sun should be avoided),
- dry,
- frost-free,
- vibration-free,
- not in potentially explosive atmospheres,
- which can be accessed for maintenance and servicing,
- which at best has little dust exposure,
- which is free from dangers due to the expansion factor or airflow sounds,
- which is free from aggressive or corrosion-promoting substances.



The adsorption dryer must only be operated within the allowable operating conditions. These are defined on the type plate and vessel plate.

Any other use is considered improper and the manufacturer accepts no liability.

The adsorption dryer must not be converted in any way and its components must not be modified. The use of components other than the original ones from the manufacturer is not permitted, unless this has been agreed with the manufacturer.

The values shown on the vessel plate are the maximum permissible values as per the pressure equipment directive. These values are not directed at the operating conditions. The maximum operating conditions can be found on the type plate of the adsorption dryer.

For the nominal performance data of the adsorption dryer, please refer to the Section "Performance data".

Exceeding or even significantly undercutting the design data can lead to bad pressure dewpoints!

The compressed air supplied to the device must be of the following quality:

- Free from aggressive and corrosive substances
- Free from particles and solids
- Moisture-saturated
- Must be within the temperature conditions for the design.



In principle, the adsorption dryer can also be operated without any pre-treatment, but this may be detrimental to the service life of the adsorbent. Droplets of oil and particles are stored in the open pores and reduce the adsorption capacity of the adsorbent.



Where temperatures are above 55°C, previously collected moisture can be released again or can no longer be absorbed!

2.2 Performance data

The performance data of the individual types of devices is shown in the table below. The data is based on the operating conditions of the compressed air temperature + 35°C and 7 bar operating pressure, and a moisture content of the compressed air of 100 %.

Type	Nominal volumetric flow rate m ³ /h	Connection
DRYBERG® AD150 CT	150	1"
DRYBERG® AD180 CT	180	1"
DRYBERG® AD210 CT	210	1"
DRYBERG® AD340 CT	340	1 ½"
DRYBERG® AD480 CT	480	1 ½"
DRYBERG® AD600 CT	600	1 ½"
DRYBERG® AD820 CT	820	2"
DRYBERG® AD1000 CT	1000	2"
DRYBERG® AD1200 CT	1200	2"

Based on 1 bar(a) and 20°C

Classification acc. to DGRL 2014/68/EU	DRYBERG® AD150-210-CT Category II
Classification acc. to DGRL 2014/68/EU	DRYBERG® AD340-820-CT Category III
Classification acc. to DGRL 2014/68/EU	DRYBERG® AD1000-1200-CT Category IV
Fluid group	2
Supply voltage	230 V, 50-60 Hz
Safety class	IP 54
Min. / max. allowable pressure	4 / 16 bar
Sound pressure level (free-field measurement in distance of 1.5m)	up to 80 dB (A)
Min. / max. temperature	+2 to 50 °C



Routine inspections must be carried out on the pressure vessels. The operator is solely responsible for the registration. Regional or national regulations may apply in addition. Please also refer to the additional vessel documentation!

3. Safety notes

The DRYBERG® AD-CT adsorption dryers have been built according to state-of-the-art technology and the latest safety regulations. However, there is still a risk of danger during operation, maintenance, installation and servicing, and during transport and setup. In particular, the disregard of safety regulations when handling compressed air may result in serious injury or death. Expertly trained personnel and those trained in safety should therefore only use the system.



- Observe the safety notes in this manual and on the adsorption dryer.
- Observe all safety notes, even those in the individual chapters.
- Observe all legal guidelines and safety regulations (the latter may vary from region to region!)
- Observe all local site regulations which are stipulated for the field of application.



3.1 Signs and symbols

The following signs are affixed to the adsorption dryer:

- **Vessel plate** (on the front underneath the pressure gauge)
it includes details of the year of manufacture, vessel number, max. permissible temperature, maximum permissible pressure, volume, min. temperature, test pressure and test date.
- **Type plate**
it shows details of the type, year of manufacture, serial number of the device, performance data, weight and filters installed.

Only once on the adsorption dryer:

Type plate:

Typ / Type	max. Druck / max. Pressure
S-Nr. / S-No.	Spannung / Voltage
Leistung / Capacity	Vorfilter / Prefilter
m ³ /h bei / at bar g	Nachfilter / Final filter
Baujahr / Built	
Gewicht / Weight (kg)	CE
kg	Made in Germany
 Vor Inbetriebnahme und Service das Handbuch lesen. Read the manual before operation and service.	 Gefahr durch Druckluft! Danger! Compressed air

The type plates on the device show important information. Please make sure that they are always legible and that they can be accessed.

3.2 Danger zones

Risk from pressure-bearing parts

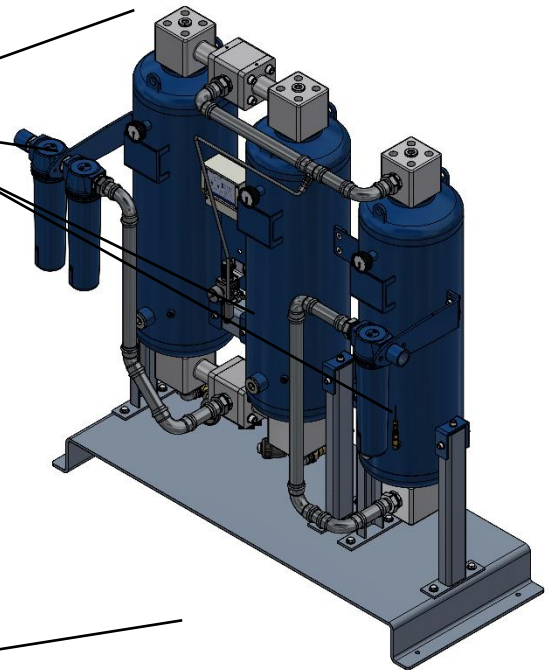

Risk of slipping due to spilt desiccant on the floor



- Never operate the device outside of the load limits shown on the vessel plate.

- Never carry out work as long as the device is under pressure.



- Do not modify the structure of the device or change its function.

- Only use the adsorption dryer for its intended purpose.

- Do not climb onto the device.



- Do not carry out welding work on pressure-bearing parts.

- Wear respiratory protection and eye protection when changing the desiccant.

- Risk of slipping due to spilt desiccant.



- Always check that the silencers are secure and wear eye protection.

- Never operate the device if there is apparent damage.

- Avoid sparks and naked flames in the vicinity of the desiccant.



- Never lift the device by the equipment parts, only use the lifting lugs.

- Only carry out work on the device if it has been disconnected from the power supply.

Adsorbents

The desiccants and the activ carbon used do not fall into the hazardous substances group and are therefore not subject to labelling requirements. Nevertheless, please observe all common safety measures with regard to using chemicals. Please also wear your personal protective equipment (goggles and respiratory protection). Please also note that the material accumulates contaminants, including oil vapour parts. This can cause additional dangers. Should you require further information, contact the manufacturer to obtain a copy of the safety datasheet for the desiccant and active carbon.

4. Technical product data

4.1 Equipment overview, front view

- 1- Compressed air inlet
- 2- Compressed air outlet
- 3- Draining nozzle desiccant
- 4- Controller
- 5- Prefilter (two stages)
- 6- After-filter
- 7- Pressure gauge
- 8- Vessel type plate
- 9- Manual drain after-filter
- 10-Condensate drain prefilter
- 11-Lifting lugs
- 12-Oil test indicator
- 13-Changeover valve inlet
- 14-Changeover valve outlet
- 15-Dewpoint sensor (optional)

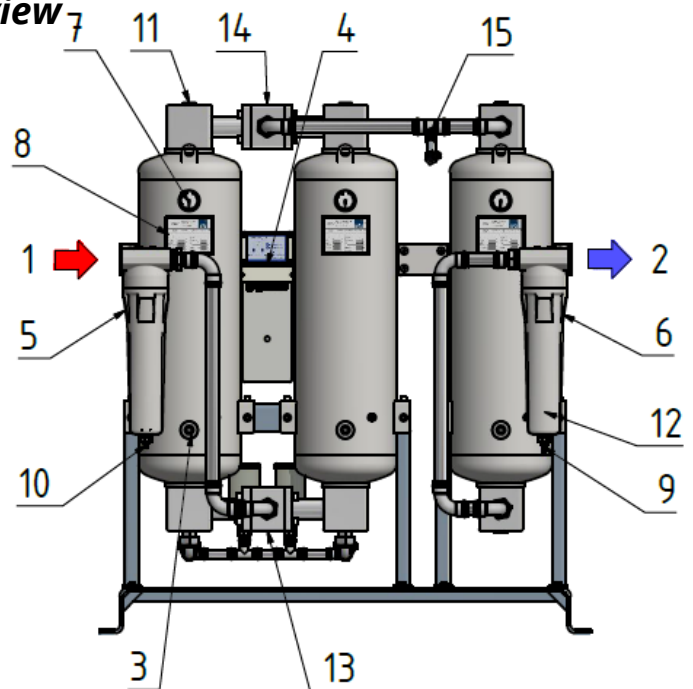

4.2 Equipment overview, rear view

1. Removable screw connection, bottom
2. Lifting lugs
3. Silencer
4. Solenoid valve
5. Purge air jet (internal)
6. Flanged pipe bridge with diffuser

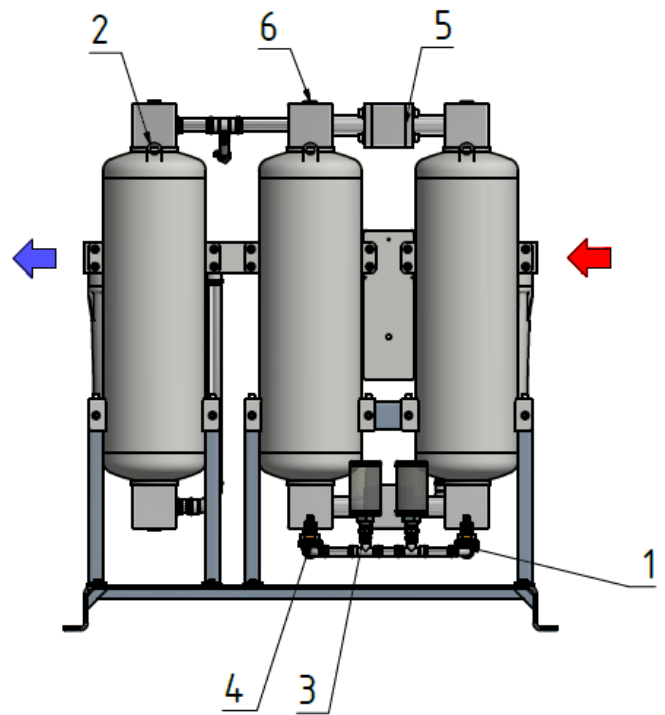

4.3 Function description



From the filled adsorbent material, (desiccant in this case), moisture is stored in the large, open pores of the adsorbent material, thus reducing the moisture content in the compressed air.

Through the joining pipe and possible pre-treatment, the compressed air is fed via the inlet into the diffuser (flow distributor and sieve). The compressed air is hereby distributed over the whole vessel cross-section for optimum efficiency. Based on the laws of physics and a calculated and required contact time, the abovementioned moisture content is stored in the open pores of the desiccant. The cleaned compressed air then exits the vessel again through a sieve on the outlet.

As the temperatures rise, the performance of the desiccant is reduced since the so-called adsorption heat builds up in the desiccant as the amount of moisture increases and as temperatures exceed 55 °C, the stored moisture is then released again from the agent, i.e. no more moisture is stored.

The moisture stored in the desiccant gradually saturates the material. During the course of the defined adsorption phase, the desiccant bed is optimally used. After a predetermined time, the desiccant is then desiccated again following the counter-flow principle using the dried compressed air, which is removed from the dry output flow through a nozzle. This process constantly switches between the two vessels. With the appropriate compressed air quality at the inlet, it is possible for the service

life of the desiccant to exceed well over 10,000 hours. Over the piping the air then is lead to the oil vapour adsorber.

Operating principle:

B1 / B2 = Behälter / vessel
 B3 = Aktivkohlebehälter / activated carbon vessel
 PI = Manometer / pressure gauge
 V1 / V2 = Wechselventil / change valve
 V3/4 = Expansionsventil / exhaust valve

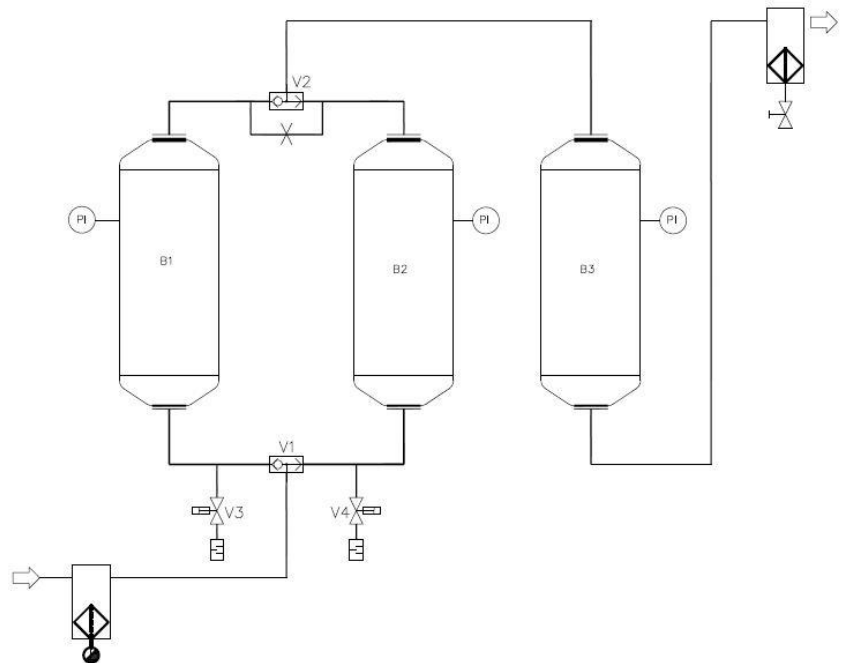
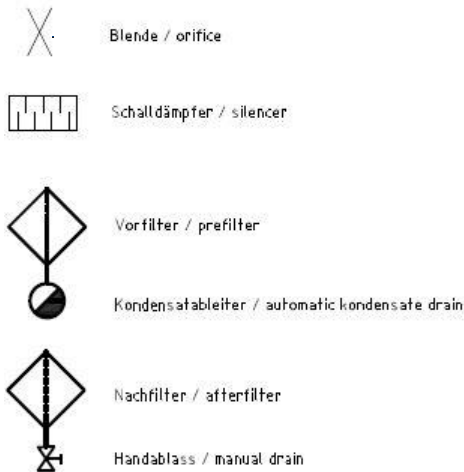

From the filled adsorbent material, (active carbon in this case), oil vapours and odorous and aromatic substances are stored in the open pores of the active carbon, thus reducing its content in the compressed air.

Through the joining pipe and possible pre-treatment, the compressed air is fed via the inlet into the diffuser (flow distributor and sieve). The compressed air is hereby distributed over the whole vessel cross-section for optimum efficiency. Based on the laws of physics and a predetermined contact time, the abovementioned contaminations are stored in the open pores of the active carbon. The cleaned air then exits the vessel again through a sieve on the outlet.

As the temperatures rise, the performance of the active carbon is reduced since the hydrocarbon chains (oils) become shorter and shorter and cannot be absorbed as effectively.

The contaminations collected in the active carbon gradually saturate the material. It cannot be regenerated in the process and must be replaced. With the appropriate compressed air quality at the inlet, it is possible for the service life to exceed 10,000 hours.

5. Monitoring the operation

The following equipment is available for regular monitoring:

The pressure gauges display the operating pressure. They provide information about the regular switch-over of the adsorption dryer.



The EVERMATIC control unit uses LEDs to display the status of the adsorption dryer.

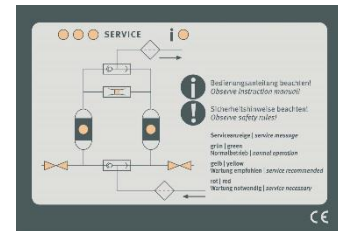

If a dew point controller is used, then the operating status is also shown.

When daily checks are carried out, observe the noises which are caused by the regeneration process. The pressure gauges should also be observed. The expansion and noises of the purging air should always be regular. Interruptions in the flow noises could indicate a defective solenoid valve or control fault.

The oil check indicator is used to regularly measure the residual oil. The needle valve is only opened for the duration of the measurement. Based on the discolouration, the indicator provides information about the saturation of the active carbon.



When daily checks are carried out, be mindful of any noises which are caused by the regeneration process. The pressure gauges should also be taken into consideration here. The expansion and noises of the purging air should always be regular. Brief interruptions in the flow noises for example indicate a defective solenoid valve or control fault.

6. Transport, storage and setup

6.1 Transport

i Although great care is taken, please check immediately whether the adsorption dryer has been damaged in any way. Any kind of transportation damage must be pointed out immediately to the deliverer and manufacturer.

- Suitable hoisting equipment must be provided for the transportation, loading and unloading process.
- The device must only be lifted at the designated points: lifting lugs or transport pallet.
- Take the weight of the adsorption dryer into account and provide suitable assistive equipment.
- Secure the adsorption dryer against tilting using suitable means.
- Do not remove the packaging material until the device is moved to its place of installation.
- Only appropriately qualified personnel may carry out the abovementioned tasks.
- Observe all regulations on accident prevention.

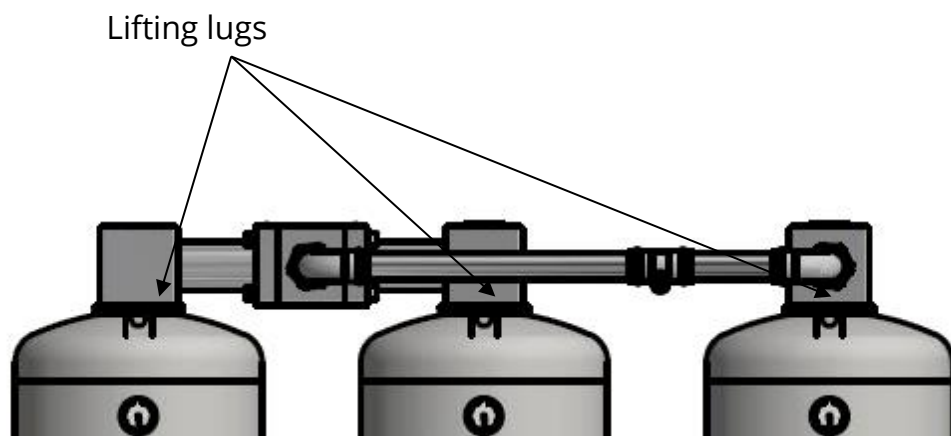

6.2 Storage

i If the device needs to be stored before being commissioned, ensure that the storage site fulfills the following requirements:

- Indoors only
- Dry
- Frost-free
- Protected against weather impact.



If the device is stored after having been commissioned, please proceed as follows:

- Depressurise the adsorption dryer.
- Disconnect the adsorption dryer from the compressed air system.
- Close the compressed air inlet and outlet.

6.3 Setup



Please refer to the setup conditions described in Section 2.1. The basic data required for the setup can be found in the Performance data in Section 2.2.

When setting up, make sure

- that the ground is level and capable of carrying the weight. Please also take into account that the vessel will be filled with water during the routine inspection.
- Make sure there is enough space around the adsorption dryer to carry out the servicing and maintenance work. We recommend at least 0.8m.
- Make sure that the adsorption dryer can be reached and accessed by the lifting gear.
- The adsorption dryer must not be accessible to non-experts, or warning signs should be affixed for inexperienced persons.
- The adsorption dryer cannot be rammed by haulage vehicles.
- The signage is clearly visible at all times.

There are mounting holes in the base section of the adsorption dryer. These should be used to anchor the device into the ground, as long as the ground allows it.

7. Installation

7.1 Recommendations for installation



Proper installation is the basic prerequisite for the safe and problem-free operation of the DRYBERG® AD-CT series.

We recommend the installation of shut-off devices both upstream and downstream of the adsorption dryer. The adsorption dryer can thereby be disconnected from the compressed air system during maintenance.

If operation cannot be interrupted during maintenance then a by-pass line must be provided. It should at least include a filter combination DMF and SMA to prevent a contamination of moisture in liquid form downstream of the adsorption dryer.



We recommend installation after a corresponding pre-treatment. Filters and separators should already be installed prior to this to prevent the rapid saturation of the prefilter which is part of the delivery. The adsorption dryer is usually installed behind an air cauldron.

A filter with a separation degree of 0.01 μ must be installed immediately in front of the adsorption dryer (included in the delivery) to collect any possible additional liquid drops and solids which would otherwise close up the open pores of the adsorbent material for the drying process.

Installing the device behind an air cauldron also has the advantage in that pulsating compressed air is buffered and the temperature at the inlet of the adsorption dryer is lower because it cools down in the air cauldron.

Choose a place of installation with the lowest possible compressed air temperature and with the highest level of saturated compressed air. This then increases the service life of the desiccant and the adsorption dryer works most efficiently.

When installing an air cauldron, make sure that:

- There is no reverse flow (e.g. install a non-return valve)
- The compressed air inlet temperature does not exceed the maximum permissible value
- Pressure shocks or pulsating compressed air are buffered by the corresponding filters
- The condensate separation of the prefiltration works properly

7.2 Demands on the installation

Prior to installation, check the following points:



- The compressed air system and the adsorption dryer must be free from pressure.
- For compressed air systems which need to remain under pressure, shut-off devices have to be protected against unintentional opening.
- The operating pressure in the system cannot be higher than the maximum permissible operating overpressure of the adsorption dryer.

- There must be no pressure surges in the system in the desiccant (e.g. from valves which open abruptly).
- The pipelines are designed for the operating pressure, nominal width and volume.
- No possible vibration transmission or vibration.
- No residue left in the pipeline from mechanical processing.

7.3 Elimination of hazards

Please be aware of the risks associated with the installation of the device:



- Do not work on parts which are under pressure.
- The pipelines must be held in place with brackets, the adsorption dryer is not designed to act as a support for the pipes.
- The adsorption dryer must only be used in the predetermined operating conditions (see vessel plate), it is the operator's duty to observe these values.

8. Commissioning



All work on DRYBERG® AD-CT adsorption dryers and on the feeder and drainage systems must only be carried out by expertly trained persons and by those with experience in the field of compressed air!

8.1 Commissioning prerequisite

The following points must be checked immediately prior to commissioning:



- The maximum operating values must not be exceeded.
- Upstream and downstream shut-off devices are closed.
- All connections and screw connections are secure. Check this and tighten if necessary using a suitable tool.
- Visually check again for any signs of damage. Do not use the adsorption dryer if it is damaged in any way.

8.2 Pressurisation



Only once you've successfully completed all of the checks listed in Section 8.1 can you perform the following steps in the specified order.



Wear ear protection for this as the flow noise can get very loud.

1. Make sure that the compressed air system is under pressure upstream of the adsorption dryer.
2. Slowly open the cut-off valve upstream of the adsorption dryer until you hear the flow noise.
3. Keep an eye on the pressure gauge on the vessel. Pressurisation must rise slowly.
4. At 4 bar, close the shut-off device again at the inlet. Check all connections for leaks. If leaks are found, the adsorption dryer must be rendered pressureless again and the leaks must be repaired.
5. If no further flow noises can be heard and if the pressure gauge does not indicate any further increase in pressure, you can open the cut-off valve completely.
6. Only then switch on the adsorption dryer controller.

8.3 Mains operation

Pressurisation has been successful. Check whether the compressed air system downstream of the adsorption dryer can be opened safely. Then proceed as follows:



1. Slowly open the cut-off valves at the outlet of the adsorption dryer until you hear the flow noise.
2. Keep an eye on the pressure gauge. Should the pressure suddenly drop, check whether any tapping points are still open.
3. If the pressure remains stable and you no longer hear any flow noise, the cut-off valve downstream of the adsorption dryer can be opened completely.



4. Start the controller. Once switched on, it can take 1 minute until the first valve is opened.
5. Keep an eye on the pressure gauges. The operating pressure must be virtually "0" on the expanding side. The expansion noise is loud, only quiet flow noises should be perceived after this.
6. Once regeneration has been completed, pressurisation starts. During this time, the previously opened valve must be closed and pressurisation must start again.

7. Once the pressurisation time has passed, the pressure on both vessels must be virtually the same.
8. Now also take into account the expansion (regeneration) on the other side. If this also works as described above, the adsorption dryer is ready for operation.

8.4 Disconnecting from the mains



Should you have to disconnect the adsorption dryer from the mains, e.g. for a maintenance operation, make sure that this work is only carried out when the device is free from pressure.



Wear your personal protective equipment. Proceed as follows:



1. Close the cut-off valves at the inlet and outlet of the adsorption dryer.
2. Open the manual drain on the after-filter housing.

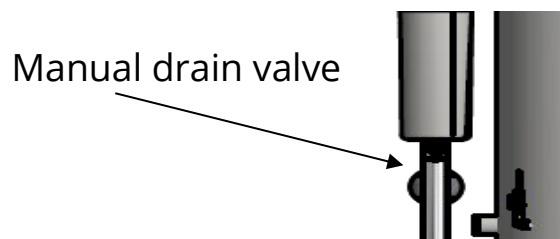

3. Keep an eye on the pressure gauge and wait until it displays "0" bar before starting work.
4. Then close the manual drain valve again.

Instead of using the manual drain, you can also depressurise the adsorber vessels by allowing the controller to continue to run upstream and downstream of the dryer if the shut-off devices are closed, until both sides are depressurised.

The adsorption dryer is now disconnected from the mains.

9. Maintenance



Maintenance work may only be carried out by suitably qualified personnel! Make sure that the device is free from pressure before starting work and observe the applicable accident prevention regulations for the place of installation!

9.1 Regular maintenance work

The following table gives an overview of the intervals and scope of the maintenance work:

Maintenance of	Activity	Every day	Every month	Every 12 months	Every 24 months	Every 48 months
Pressure gauge and controller	Visual check, functional check	X				
Control box	Check that the cables and terminals are securely fixed			X		
Silencer	Clean			X		
	Replace				X	
Prefilter and after-filter element	Replace the filter element			X		
Desiccant	Replace					X
Active carbon	Replace			X		
Sieves / diffuser	Clean, replace if necessary				X	
O-rings of filter housing	Replace				X	
Piston changeover valves	Replace				X	
Solenoid valves	Replace				X	
Pressure dew point sensor (if installed)	Recalibrate				X	
Seals	Replace			X		
Oil check indicator	Residual oil content measurement		X			
Oil check indicator	Replace pipe if discoloured	if necessary				

9.2 Daily checks

The following points should be checked every day:

- The difference in the operating pressure upstream and downstream of the adsorption dryer is not more than 0.5 bar.

- Open the manual drain valve slightly on the after-filter. It must not drip.
- Check if you can hear any unusual or loud noises.
- Check for leaks.
- If prefilters are installed, check that the condensate drains work properly.

9.3 Checking the pressure dewpoint and the residual oil content

If a pressure dewpoint controller is installed, the pressure dewpoint is displayed. You can then set the pressure dewpoint according to your requirements.

With the standard package, the EVERMATIC (time control only) is already installed. Since this controller can't measure the pressure dewpoint, you should measure it externally from time to time.

Determine a measuring point behind the dryer and connect an external measuring device. Make sure that this measurement is used in accordance with the manufacturer specifications and that it is suitable for the pressure dewpoint range of the adsorption dryer which is to be measured. Record these values in order to be able to track the course of the pressure dewpoint.

The residual oil content should be measured on a regular basis. Proceed as follows:



1. Check that the indicator pipe is secure.
2. Record the date and time when measurements start.
3. Record the operating pressure (it should be constant during the measurement).
4. Record the scale value where the obvious red discolouration can already be seen. (ignore any slight pink-coloured discolouration)
5. Open the needle valve completely.
6. Allow the measurement to run its course until there is a discolouration of a scale unit of at least 0.2. Use the following tables with the corresponding measurement pressure to determine the ppm content for the corresponding measurement time.

7. If your measurement value is within the table values (e.g. 0.5 scale units are discoloured), you can interpolate this value.
 8. Multiply this value by 1.2 to obtain the residual oil content in mg/m³.
 9. Also assess the discolouration rate by recording the values at regular intervals. This provides you with information about the service life of the active carbon.
 10. You can use the test pipe until it is completely discoloured, then replace it.
 11. An example at the end of the table clarifies the selection.
 12. Close the needle valve again. If more measurements need to be taken, continue to measure from the obvious red discoloured area.
- Replace the completely discoloured test pipe when the device is depressurised.

Table for measurement pressure **greater than 7 bar (g)**, residual oil content in **ppm**

Scale	0,2	0,4	0,6	0,8	1,0	1,2	1,4	1,6
Duration in h								
4	0,548	1,096	1,644	2,192	2,740	3,288	3,836	4,384
4,5	0,496	0,992	1,488	1,984	2,480	2,976	3,472	3,968
5	0,452	0,904	1,356	1,808	2,260	2,712	3,164	3,616
5,6	0,404	0,808	1,212	1,616	2,020	2,424	2,828	3,232
6,3	0,358	0,716	1,074	1,432	1,790	2,148	2,506	2,864
7,2	0,312	0,624	0,936	1,248	1,560	1,872	2,184	2,496
8,4	0,270	0,540	0,810	1,080	1,350	1,620	1,890	2,160
10	0,224	0,448	0,672	0,896	1,120	1,344	1,568	1,792
12,5	0,180	0,360	0,540	0,720	0,900	1,080	1,260	1,440
16,6	0,136	0,272	0,408	0,544	0,680	0,816	0,952	1,088
25	0,090	0,180	0,270	0,360	0,450	0,540	0,630	0,720
33	0,068	0,136	0,204	0,272	0,340	0,408	0,476	0,544
50	0,045	0,090	0,135	0,180	0,225	0,270	0,315	0,360
56	0,040	0,079	0,119	0,158	0,198	0,238	0,277	0,317
63	0,036	0,072	0,109	0,145	0,181	0,217	0,253	0,290
72	0,032	0,064	0,096	0,128	0,160	0,192	0,224	0,256
84	0,027	0,055	0,082	0,110	0,137	0,164	0,192	0,219
100	0,023	0,045	0,068	0,090	0,113	0,136	0,158	0,181
125	0,018	0,036	0,055	0,073	0,091	0,109	0,127	0,146
166	0,014	0,028	0,041	0,055	0,069	0,083	0,097	0,110
250	0,009	0,018	0,026	0,035	0,044	0,053	0,062	0,070
500	0,004	0,009	0,013	0,018	0,022	0,026	0,031	0,035
1000	0,002	0,004	0,006	0,008	0,010	0,012	0,014	0,016

Table for measurement pressure **6 bar (g)**, residual oil content in **ppm**

Scale	0,2	0,4	0,6	0,8	1,0	1,2	1,4	1,6
Duration in h								
4	0,640	1,280	1,920	2,560	3,200	3,840	4,480	5,120
4,5	0,580	1,160	1,740	2,320	2,900	3,480	4,060	4,640
5	0,524	10,48	1,572	2,096	2,620	3,144	3,668	4,192
5,6	0,454	0,908	1,362	1,816	2,270	2,724	3,178	3,632
6,3	0,416	0,832	1,248	1,664	2,080	2,496	2,912	3,328
7,2	0,364	0,728	1,092	1,456	1,820	2,184	2,548	2,912
8,4	0,312	0,624	0,936	1,248	1,560	1,872	2,184	2,496
10	0,266	0,532	0,798	1,064	1,330	1,596	1,862	2,128
12,5	0,210	0,420	0,630	0,840	1,050	1,260	1,470	1,680
16,6	0,160	0,320	0,480	0,640	0,800	0,960	1,120	1,280
25	0,105	0,210	0,315	0,420	0,525	0,630	0,735	0,840
33	0,078	0,156	0,234	0,312	0,390	0,468	0,546	0,624
50	0,053	0,106	0,158	0,211	0,264	0,317	0,370	0,422
56	0,047	0,093	0,140	0,186	0,233	0,280	0,326	0,373
63	0,042	0,083	0,125	0,166	0,208	0,250	0,291	0,333
72	0,037	0,074	0,110	0,147	0,184	0,221	0,258	0,294
84	0,032	0,064	0,096	0,128	0,160	0,192	0,224	0,256
100	0,027	0,054	0,080	0,107	0,134	0,161	0,188	0,214
125	0,020	0,041	0,061	0,082	0,102	0,122	0,143	0,163
166	0,016	0,032	0,048	0,064	0,080	0,096	0,112	0,128
250	0,011	0,021	0,032	0,042	0,053	0,064	0,074	0,085
500	0,005	0,010	0,016	0,021	0,026	0,031	0,036	0,042
1000	0,003	0,005	0,008	0,010	0,013	0,016	0,018	0,021

Table for measurement pressure **5 bar (g)**, residual oil content in **ppm**

Scale	0,2	0,4	0,6	0,8	1,0	1,2	1,4	1,6
Duration in h								
4	0,700	1,400	2,100	2,800	3,500	4,200	4,900	5,600
4,5	0,700	1,400	2,100	2,800	3,500	4,200	4,900	5,600
5	0,636	1,272	1,908	2,544	3,180	3,816	4,452	5,088
5,6	0,568	1,136	1,704	2,272	2,840	3,408	3,976	4,544
6,3	0,500	1,000	1,500	2,000	2,500	3,000	3,500	4,000
7,2	0,438	0,876	1,314	1,752	2,190	2,628	3,066	3,504
8,4	0,380	0,760	1,140	1,520	1,900	2,280	2,660	3,040
10	0,316	0,632	0,948	1,264	1,580	1,896	2,212	2,528
12,5	0,254	0,508	0,762	1,016	1,270	1,524	1,778	2,032
16,6	0,190	0,380	0,570	0,760	0,950	1,140	1,330	1,520
25	0,126	0,252	0,378	0,504	0,630	0,756	0,882	1,008
33	0,096	0,192	0,288	0,384	0,480	0,576	0,672	0,768
50	0,062	0,124	0,186	0,248	0,310	0,372	0,434	0,496
56	0,057	0,114	0,172	0,229	0,286	0,343	0,400	0,458
63	0,050	0,101	0,151	0,202	0,252	0,302	0,353	0,403
72	0,044	0,088	0,132	0,176	0,220	0,264	0,308	0,352
84	0,038	0,076	0,114	0,152	0,190	0,228	0,266	0,304
100	0,032	0,064	0,096	0,128	0,160	0,192	0,224	0,256
125	0,026	0,051	0,077	0,102	0,128	0,154	0,179	0,205
166	0,018	0,037	0,055	0,074	0,092	0,110	0,129	0,147
250	0,013	0,027	0,040	0,054	0,067	0,080	0,094	0,107
500	0,006	0,012	0,018	0,024	0,030	0,036	0,042	0,048
1000	0,003	0,006	0,009	0,012	0,015	0,018	0,021	0,024

Example of determining the ppm rate:

The measurement is taken at an operating pressure of 6 bar over a period of 50 hours. 0.5 scale units of discolouration have been added.

Using Table 6 bar, select 50 hours. To interpolate to 0.5 scale units, calculate:

$0.106 + 0.158 = 0.264 \text{ ppm} / 2 = 0.132 \text{ ppm}$ based on the measurement time of 10 hours

Converted into mg/m^3 , this means:

0.132×1.2 (factor for compressor oils) = 0.158 residual oil content in mg/m^3

9.4 Overview of maintenance parts

9.4.1 Annual maintenance

The following maintenance parts should be replaced every 12 months:

Type	Component	Description	Qty	Interval	Measure
AD150 CT		Filter elements	2	Every year	Replace
	INDI	Oil check pipe	1	Every year / when required	Replace
	AK-CT0150	Filling active carbon	1	Every 48 months/ when required	Replace
AD180 CT		Filter elements	2	Every year	Replace
	INDI	Oil check pipe	1	Every year / when required	Replace
	AK-CT0180	Filling active carbon	1	Every 48 months/ when required	Replace
AD210 CT		Filter elements	2	Every year	Replace
	INDI	Oil check pipe	1	Every year / when required	Replace
	AK-CT0210	Filling active carbon	1	Every 48 months/ when required	Replace
AD340 CT		Filter elements	2	Every year	Replace
	INDI	Oil check pipe	1	Every year / when required	Replace
	AK-CT0340	Filling active carbon	1	Every 48 months/ when required	Replace
AD480 CT		Filter elements	2	Every year	Replace
	INDI	Oil check pipe	1	Every year / when required	Replace
	AK-CT0480	Filling active carbon	1	Every 48 months/ when required	Replace
AD600 CT		Filter elements	2	Every year	Replace
	INDI	Oil check pipe	1	Every year / when required	Replace
	AK-CT0600	Filling active carbon	1	Every 48 months/ when required	Replace
AD820 CT		Filter elements	2	Every year	Replace
	INDI	Oil check pipe	1	Every year / when required	Replace
	AK-CT0820	Filling active carbon	1	Every 48 months/ when required	Replace

AD1000 CT		Filter elements	2	Every year	Replace
	INDI	Oil check pipe	1	Every year / when required	Replace
	AK-CT1000	Filling active carbon	1	Every 48 months/ when required	Replace
AD1200 CT		Filter elements	2	Every year	Replace
	INDI	Oil check pipe	1	Every year / when required	Replace
	AK-CT1200	Filling active carbon	1	Every 48 months/ when required	Replace

9.4.2 Two-year maintenance

The following maintenance parts should be replaced every 24 months:

Type	Component	Description	Quantity	Interval	Measure
AD150 CT	KIT-AD0150	Functional components set	1	Every 24 months	Replace
	AM-AD0150	Desiccant filling	1	Every 48 months/ when required	Replace
AD180 CT	KIT-AD0180	Functional components set	1	Every 24 months	Replace
	AM-AD0180	Desiccant filling	1	Every 48 months/ when required	Replace
AD210 CT	KIT-AD0210	Functional components set	1	Every 24 months	Replace
	AM-AD0210	Desiccant filling	1	Every 48 months/ when required	Replace
AD340 CT	KIT-AD0340	Functional components set	1	Every 24 months	Replace
	AM-AD0340	Desiccant filling	1	Every 48 months/ when required	Replace
AD480 CT	KIT-AD0480	Functional components set	1	Every 24 months	Replace

	AM-AD0480	Desiccant filling	1	Every 48 months/ when required	Replace
AD600 CT	KIT-AD0600	Functional components set	1	Every 24 months	Replace
	AM-AD0600	Desiccant filling	1	Every 48 months/ when required	Replace
AD820 CT	KIT-AD0820	Functional components set	1	Every 24 months	Replace
	AM-AD0820	Desiccant filling	1	Every 48 months/ when required	Replace
AD1000 CT	KIT-AD1000	Functional components set	1	Every 24 months	Replace
	AM-AD1000	Desiccant filling	1	Every 48 months/ when required	Replace
AD1200 CT	KIT-AD1200	Functional components set	1	Every 24 months	Replace
	AM-AD1200	Desiccant filling	1	Every 48 months/ when required	Replace

9.5 Replacing the filter elements

The prefilter of the adsorption dryer retains particles and liquid forms of oil and water, thereby protecting the desiccant against contamination. The job of the after-filter is to stop any abrasion dust that has built up from the desiccant. Proceed as follows to replace these filter elements:

1. Close the cut-off valves upstream and downstream of the adsorption dryer.
2. Open the manual drain on the filter and wait until the pressure gauge on the adsorption dryer shows "0" bar.
3. Turn the bottom part of the filter in a clockwise direction to open it. Unscrew it completely and carefully put it down.
4. Now you can remove the filter element out of the filter.
5. Use a damp cloth to clean inside the filter housing.

6. Check the O-ring in the filter head is OK. Replace if necessary.
7. Please fit the new filter element into the three pockets, on the inside of the filter bowl.
8. Screw the bottom part of the filter back in again and close the manual drain.
9. Slowly open the shut-off device at the outlet and check for leaks.
10. Once the pressure is back to normal again, slowly open the shut-off device at the outlet.

9.6 Replacing the desiccant

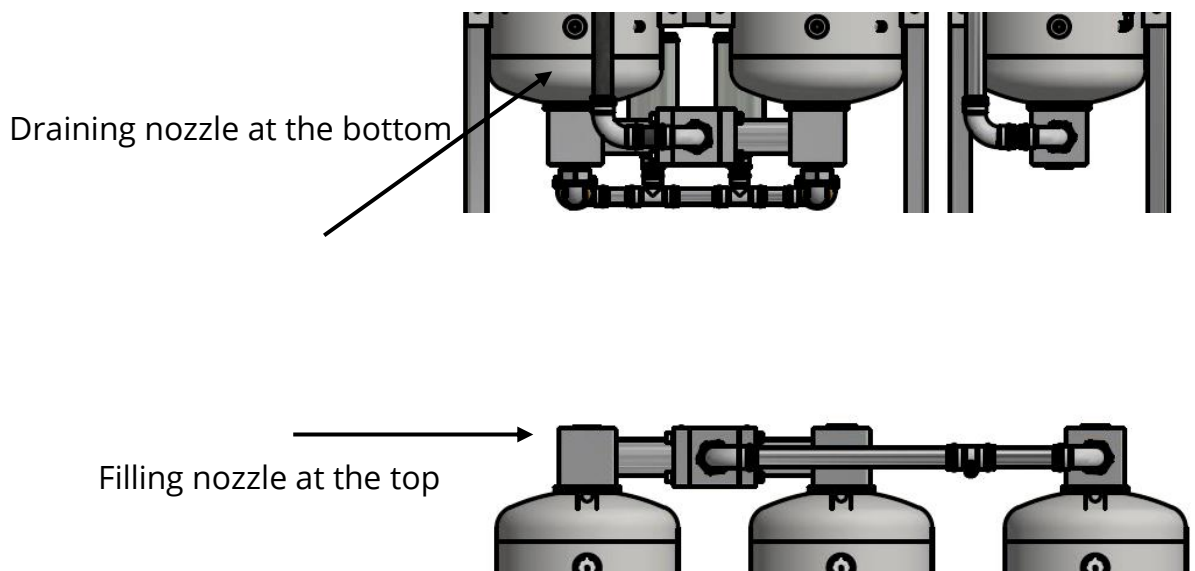

When replacing the desiccant, make sure to wear your personal protective equipment, namely the respiratory protection and goggles.



Risk of slipping if material is spilt!



The service life of the desiccant is hugely dependent on the quality of the compressed air at the inlet of the adsorption dryer. Strain from oil vapour significantly reduces the service of the desiccant. In favourable conditions, the service life can exceed well over 10,000 hours. Proceed as follows to replace the desiccant:

1. Depressurise the adsorption dryer.
2. First, open the sealing plug on the top.

3. Place a collecting vessel underneath the bottom sealing plug and remove it.
4. Collect the desiccant as it runs out.
5. Empty the vessel completely. (you can also empty the vessel using a vacuum cleaner).
6. Blow through the sieves inside the vessel.
7. Close up the bottom sealing plug again and pour the new adsorption material through the top opening. Depending on its use, the desiccant can consist of several layers. Make sure that you add the materials in the correct order. WS and alumina materials generally form the water protective layer and must be added first.
8. Once you've reached the filler plug, condense the material through slight vibration of the sheath of the adsorption dryer and then top up again until the desiccant no longer condenses, even with vibration.
9. Screw the top sealing plug back in again.



We recommend that you only change the filter element after the desiccant has been changed. Likewise, only change, or at least clean the solenoid valves after the trial run. To do so, allow the adsorption dryer to run for half an hour. The dust particles that accumulate are hereby captured in the after-filter element which is to be replaced. Only then replace the filter element.

As a rule, the adsorption dryer needs several cycles before it reaches the desired pressure dewpoint. Take into account that the piping system behind the adsorption dryer may become contaminated with moisture during this phase. You may need to provide a blow-off line during the installation operation.



Contaminated desiccant must be disposed of in accordance with the local regulations! As a rule, the disposal code is:

"Used, non-contaminated desiccant" with the disposal code number: 06 08 99
If other toxic or hazardous substances have been stored, then this must be determined by the operator and the desiccant must be disposed of taking the type of contamination into consideration!



When replacing the active carbon, make sure to wear your personal protective equipment, namely the respiratory protection and goggles.



Risk of slipping if material is spilt!

The service life of the active carbon does not need to be determined with accuracy as there are many factors which can reduce or increase the service



life. In favourable conditions, the service life can exceed 10,000 hours. Proceed as follows to replace the active carbon:



10. Depressurise the adsorber.
11. First, open the sealing plug on the top (1).
12. Place a collecting vessel underneath the bottom sealing plug (2) and remove it.
13. Collect the active carbon as it runs out.
14. Empty the vessel completely.
15. Blow through the sieves inside the vessel.
16. Close up the bottom sealing plug again and pour the active carbon material through the top opening.

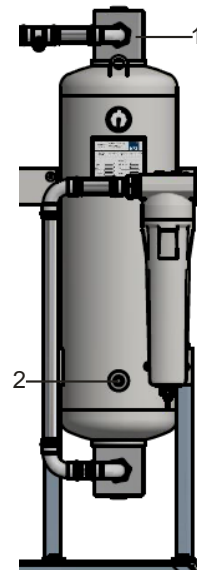

17. Fill in the activated carbon material to the lower edge of the upper diffuser. At higher filling may lead to increased dust content in the afterfilter.
18. Screw the top sealing plug back in again.

We recommend that you only change the filter element after the active carbon has been changed. To do so, allow the adsorber to run for half an hour. The dust particles that accumulate are hereby captured in the after-filter element which is to be replaced. Only then replace the filter element.

It can happen that the compressed air which has already been dried by an adsorption dryer, becomes moist again (rising pressure dewpoint). This is due to the moisture stored in the active carbon which is rinsed again after a few days.



Contaminated active carbon material must be disposed of in accordance with the local regulations! As a rule, the disposal code is:

"Used active carbon" with the disposal code number: 06 13 02

If other toxic or hazardous substances have been stored, then this must be determined by the operator and the active carbon must be disposed of taking the type of contamination into consideration!

9.7 Replacing the pistons and cylinder liners

The change-over valves consist of a guide sleeve and a piston. These pistons are subject to a mechanical load and must be replaced after two years. Proceed as follows to replace them:

1. Depressurise the adsorption dryer.
2. Make sure that the pressure gauges show "0" and that the adsorption dryer is fully depressurised.
3. Switch off the controller.
4. Remove the screw connections. Be mindful of the seals which are inside the screw connections. The pipeline connection and both vessel connections must be disconnected here.
5. You can now remove the change-over valve by unscrewing it, as shown in the diagram below.
6. Replace the piston and seal.
7. Build the changeover valve back together again in the reverse order.
8. Make sure that the seal is positioned correctly and then tighten all removable screw connections again.
9. Repeat the same operations on the bottom side.

Screw power moments:

AD0150-0210

Connection middle part to side part Nm60 (M12)

Connection side part to flange vessel Nm80 (M12)

AD0340-1200

Connection middle part to side part Nm80 (M16)

Connection side part to flange vessel Nm100 (M16)

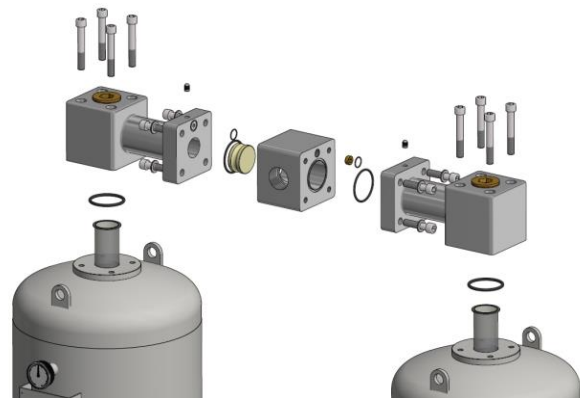

9.8 Replacing the solenoid valves

The solenoid valves are supplied fully assembled and should also be installed as such. These valves are also subject to a mechanical load and must be replaced after two years. Proceed as follows to replace them:

1. Depressurise the adsorption dryer.
2. Make sure that the pressure gauges show "0" and that the adsorption dryer is fully depressurised.
3. Switch off the controller by disconnecting the mains power plug.
4. Loosen the solenoid valve plug.
5. Loosen the removable screw connections.
6. Remove the exhaust bridge.
7. Dismantle and replace the solenoid valves. (Pay attention to direction of flow)
8. Mount the exhaust bridges again and make sure that the seal fits correctly. Tighten all screw connections again.

1. Removable screw connection
2. Solenoid valve
3. Silencer

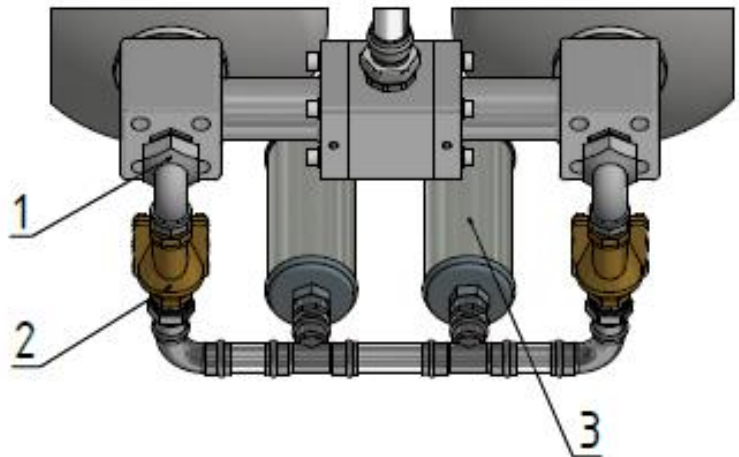

9.9 Replacing the silencers

The silencers lessen the noise generation of the regeneration process. In these silencers, proportionate desiccant abrasion in the form of dust is retained. Combined with the outgoing moist air, the silencers become clogged with dust over time and must be replaced. Proceed as follows to replace them:

1. This work must only be carried out after the device has been depressurised.
2. To do so, close the inlet and outlet shut-off devices.
3. Switch off the controller by disconnecting the mains power plug.
4. Unscrew the silencers in an anticlockwise direction from the thread.
5. Wrap a few layers of Teflon around the thread of the new silencer to make it easier to dismantle it later on. Then screw the new silencer back in again in a clockwise direction until hand-tight.
6. If the desiccant also has to be replaced, replace this first, then the silencers, then perform a trial run.

Disassembly

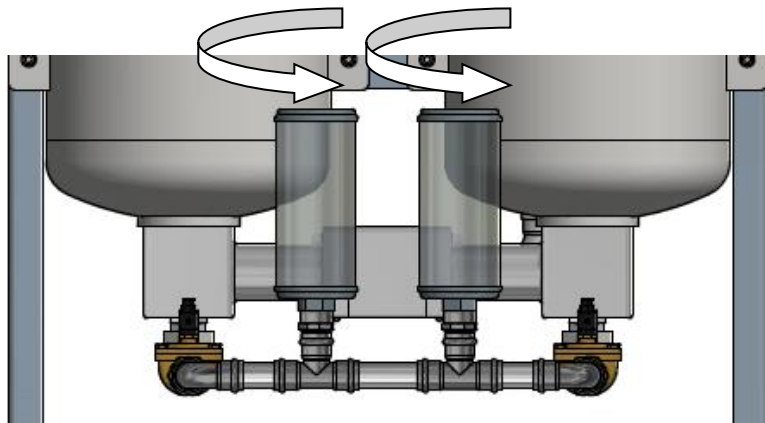

Assembly

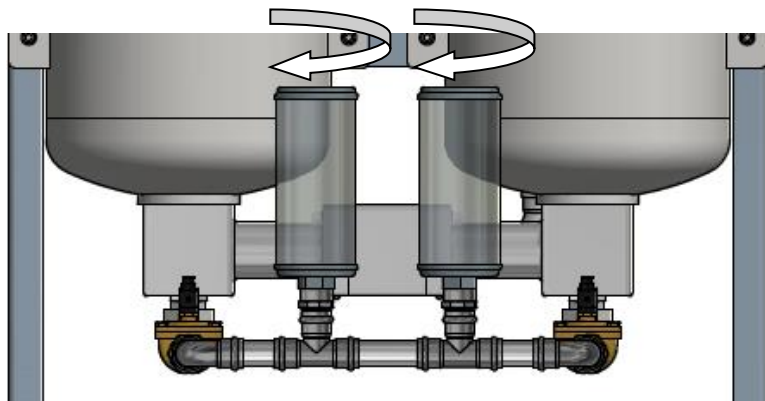

10. Replacing the pressure dewpoint sensor

If you've chosen the LDC option, you must replace the sensor element every two years. Desiccant abrasion and oil vapours can cause the accuracy of the sensors to drift. This sensor element must therefore be replaced as follows:

1. This work must only be carried out after the device has been depressurised.
2. To do so, close the inlet and outlet shut-off devices.
3. Switch off the controller by disconnecting the mains power plug.
4. Loosen the cubic plug of the sensor element.
5. Unscrew the sensor element in an anticlockwise direction.
6. Fit the new sensor element by screwing it in a clockwise direction.
7. Screw the cubic plug back onto the sensor.
8. Slowly open the inlet shut-off device until both vessels are pressurised again.
9. Check for leaks on the screw connection. If there is a leak, seal it.
10. Then start up the controller and open the shut-off device on the outlet.

Sensor in output pipe

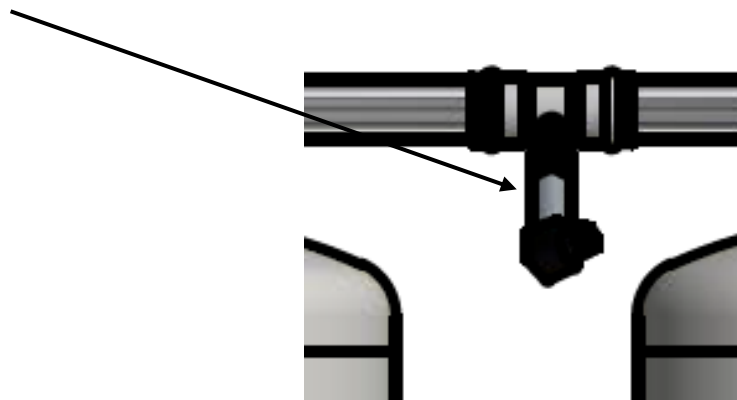

Sensor element with cubic plug



11. Faults

The following faults may occur:

Error	Possible cause	Corrective action
Device does not switch on	No power supply	Check supply voltage
	Microfuse defective	Replace fuse
Dryer does not regenerate	Controller does not work	Call Maintenance
	No power supply	Check supply voltage
	Compressor synchronisation circuit is active	Set DIL switch No. 8 to "1" (for EVERMATIC)
	Solenoid valve does not open	Check cable connection / terminals
Replace magnetic coil if necessary		
Dryer does not reach the pressure dewpoint	Desiccant not sufficiently regenerated yet	Allow it to keep running (after 48 hours at the latest, the pressure dewpoint should be reached)
	Water breakdown / oil breakthrough	Call Maintenance, replace desiccant if necessary
	Defective condensate drain	Check prefilter for buildup of condensate
	Inlet conditions incorrect (pressure, temperature)	Call Maintenance
	Compressed air extremely undersaturated	Apply moisture
	Check input parameters, possible by-pass buildup in the desiccant due to flow rate being too low	Call Maintenance
	Silencer blocked	Replace
No pressure according to pressure gauge on dryer	Inlet to dryer closed	Open the supply line
Differential pressure indicator is in red zone	Filter element is clogged	Call Maintenance

Dryer keeps returning to alarm status	Reverse flow through by-pass, reverse flow via oil vapour adsorber	Change by-pass, install non-return valve, call Maintenance
Compressors start up too frequently	Leaks	Call Maintenance
No pressurisation	Piston in undefined position	Switch off controller, allow pressurisation to take place, then switch controller back on again

Fault	Cause	Measure
Oil in the compressed air downstream of the adsorber	<ul style="list-style-type: none"> - Volumetric flow via the adsorber exceeds the intended parameters - Inlet temperature is too high - Operating pressure is too low (reduction of flow rate) - Active carbon is saturated - Large quantity of oil has broken through the compressor - Pipes / consumer downstream of the adsorber were already contaminated with oil - By-pass line is open / not sealed - Highly pulsating compressed air 	<ul style="list-style-type: none"> - Adapt to operating conditions - Upstream cooling - Replace active carbon - Close by-pass - Replace or clean pipes / consumer
Significant differential pressure	<ul style="list-style-type: none"> - Filter elements saturated 	<ul style="list-style-type: none"> - Replace elements - Check shut-off devices - Stop pressure shocks

	<ul style="list-style-type: none">- Cut-off valves not fully open- Dust fraction too high due to pressure shocks- Clogged pipes- High levels of turbulence at inlet	<ul style="list-style-type: none">- Remove active carbon from the vessel until the top dust sieve is exposed
--	--	--

12. EU Declaration of conformity

EU Declaration of conformity

We, the manufacturer,

BERG KOMPRESSOREN GmbH

hereby declare that for the systems listed below:

Adsorption dryer DRYBERG® AD0150-CT to AD1200-CT

the harmonised standards:

DIN EN ISO 12100-1-2; DIN EN ISO 14121-1; DIN EN 55011; DIN EN 61000-6-2,
61000-3-2, 61000-3-3 have been adhered to.

The conformity assessment procedure was completed in accordance with
Module A.

The pressure vessels which are part of these assemblies have been
manufactured in construction and design conforming to the European Guideline
2014/68/EU Appendix I for pressure equipment as per the technical rules of the
AD2000 instruction sheets. Separate declarations of conformity have been
issued by the manufacturer for the vessels which are supplied with this
documentation.

Any modifications made to the equipment which has not been approved by the
manufacturer will result in cancelation of this declaration.

Signed:



Martin Safari,
Managing Director