

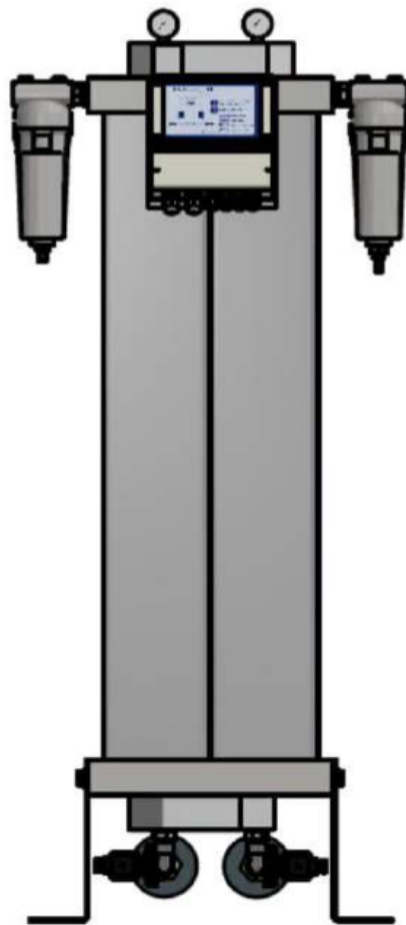

DRYBERG® AD20-110

Operating manual Adsorption Dryers



Stand: 06/2021

Contents

Contents	2
1. General information	4
1.1 System data.....	4
1.2 Contact data.....	4
1.3 Accompanying documents	5
1.4 Warranty notes	5
1.5 Operating manual	5
1.6 Signs and symbols used.....	6
2. Intended purpose / use	7
2.1 Intended use	7
2.2 Performance data.....	8
3. Safety notes	10
3.1 Signs and symbols	10
3.2 Danger zones	11
4. Technical product data	12
4.1 Equipment overview, front view	12
4.2 Equipment overview, rear view.....	13
4.3 Function description.....	13
5. Monitoring the operation	15
6. Transport, storage and setup.....	15
6.1 Transport.....	15
6.2 Storage.....	16
6.3 Setup.....	16
7. Installation	17
7.1 Recommendations for installation	17
7.2 Demands on the installation	18
7.3 Elimination of hazards	18
8. Commissioning.....	18
8.1 Commissioning requirements.....	19
8.2 Pressurisation	19
8.3 System operation	19
8.4 Disconnecting from the system	20
9. Maintenance	21
9.1 Regular maintenance work.....	21
9.2 Daily checks.....	22
9.3 Checking the pressure dew point	22
9.4 Overview of maintenance parts.....	23
9.4.1 Annual maintenance	23
9.4.2 Two- and four-year maintenance	24

9.4.3	Two-year maintenance / Tighten the screws.....	25
9.5	Replacing the filter elements.....	25
9.6	Replacing the desiccant	26
9.7	Shuttle valve piston replacement	27
9.8	Replacing the solenoid valves	30
9.9	Replacing the silencers	31
10.	Replacing the dew point sensor	32
11.	Faults	33
12.	Manufacturer's declaration	35
12.1	Manufacturer's declaration	35
13.	EU Declaration of conformity	36
14.	Certificate of Calibration (if dew point sensor is available)	37

1. General information

Please complete the following information according to the type plate, vessel plate and contract documents. This enables the manufacturer to clearly identify the dryer and makes it easier to give advice if there are queries. It also simplifies the provision of spare parts and support. This may correspond to separate pieces of equipment for the individual devices.

1.1 System data

Model:

Order No.:

Vessel No.:

Serial No.:

Year of manufacture:

Date of commissioning:

1.2 Contact data

Manufacturer of this unit is the company:

BERG Kompressoren GmbH
Medienstraße 35,
47807 Krefeld, Deutschland

Internet: www.berg-kompressoren.de

1.3 Accompanying documents

Applicable documents which are not included with this documentation:

- Installation drawing
- Documentation for additional equipment parts
- Controller documentation
- Calibration certificate (if dewpoint controller is installed)

1.4 Warranty notes

For the conditions necessary for compliance with the warranty, please refer to our "General Terms of Sale and Delivery".

The warranty shall be void if:

- The adsorption dryer is used for anything other than its intended use.
- The instructions in this operating manual are not observed.
- External influences (e.g. aggressive substances) cause damage to the adsorption dryer.
- Maintenance intervals are not been followed.
- Damage is caused due to incorrect or wrong maintenance.
- The adsorption dryer is operated in defective condition.
- An unfavourable or incorrect installation is carried out.
- The process conditions do not comply with the system concept (e.g. highly undersaturated compressed air at the inlet).

1.5 Operating manual

This operating manual will help to clarify any outstanding questions concerning the setup, installation, operation, maintenance, repair and disposal of the dryer. It contains useful tips and advices.

It is not only written for the operator who is responsible for monitoring the daily operation of the device, but also for the service personnel who performs the installation and service. Maintenance and repair work may only be carried out by qualified personnel!

This operating manual must be read before any installation and maintenance work is started. All safety instructions must be considered!

The operating manual must be accessible any time when operating the adsorption dryer.

As already mentioned in the warranty notes, the manufacturer accepts no liability for damages resulting from ignoring the instruction in the operating manual.

1.6 Signs and symbols used

The following symbols are listed in this manual and /or are affixed to the adsorption dryer:



Tip
This symbol indicates tips for the efficient use of the adsorption dryer!



Note
This symbol indicates instructions information for the safe handling of the adsorption dryer.



Caution / Warning
This symbol indicates general hazards or dangerous situations.



Danger! Compressed air
This symbol warns of dangers due to compressed air.



Danger! High voltage
This symbol warns of dangers due to electric voltage.



Slip hazard
This symbol warns of the risk of slipping.



Wear ear protection



Wear breathing protection



Wear safety glasses

These three symbols point out the necessity to wear safety equipment.

2. Intended purpose / use

The adsorption dryer is designed for removing humidity from compressed air by adsorption in industrial compressed air systems. It requires the supply of saturated compressed air from a supply source.

The main task is to reduce the humidity in the compressed air, while upstream filters and separators only ensure that particles and droplet are separated. The desiccant which is specifically designed for this purpose is used to store the water vapour from the compressed air in the pores of the adsorbent, thereby reducing the moisture content of the compressed air.

2.1 Intended use

The adsorption dryer is exclusively designed for drying compressed air! If the adsorption dryer is to be used with other gases, this must be agreed with the manufacturer. Other safety guidelines may apply here!

The adsorption dryer is set up for indoor installation, which is:



- suitable for the weight,
- weatherproof (exposure to sun should be avoided),
- dry,
- frost-free,
- vibration-free,
- not in potentially explosive atmospheres,
- can be accessed for maintenance and servicing,
- no or little dust exposure,
- free from dangers due to the expansion factor or airflow sounds,
- free from aggressive or corrosion-promoting substances.



The adsorption dryer must only be operated within the allowed operating conditions. These are defined on the type plate and vessel plate. Any other use is considered improper and the manufacturer accepts no liability.

The adsorption dryer must not be converted in any way and its components must not be modified. The use of components other than the original ones

from the manufacturer is not permitted, unless this has been agreed with the manufacturer.

The values shown on the vessel plate are the maximum permissible values as per the pressure equipment directive. These values are the max. allowed conditions but exceeding the conditions for operating performance. The maximum operating conditions can be found on the type plate of the adsorption dryer.

For the nominal performance data of the adsorption dryer, please refer to the section "Performance data".

Exceeding or even significantly undercutting the design data can lead to bad pressure dewpoints!

The compressed air supplied to the adsorption dryer must be of the following quality:

- Free from aggressive and corrosive substances
- Free from particles and solids
- Moisture-saturated
- Must be within the temperature conditions for the design.



In principle, the adsorption dryer can also be operated without any pre-treatment, but this may reduce the service life of the desiccant. Droplets of oil and particles are stored in the open pores and reduce the adsorption capacity of the desiccant also.



Where temperatures are above 55°C, previously collected moisture can be released again or can no longer be absorbed!

2.2 Performance data

The performance data of the individual types of devices is shown in the following table. The data are based on the operating conditions of the compressed air temperature + 35°C and 7 bar operating pressure, and a moisture content of the compressed air of 100 %.

Type	Nominal volumetric flow rate m ³ /h	Connection
DRYBERG® AD20	20	3/8"
DRYBERG® AD35	35	3/8"
DRYBERG® AD50	50	3/8"
DRYBERG® AD70	70	1/2"
DRYBERG® AD90	90	1/2"
DRYBERG® AD110	110	1/2"

Based on 1 bar(a) and 20°C

Classification acc. DGRL 2014/68/EG	DRYBERG® AD20 Art.4 Abs.3
Classification acc. DGRL 2014/68/EG	DRYBERG® AD35 ... 110 Category I
Fluid group	2
Supply voltage	230 V, 50-60 Hz
Protection class	IP 54
Min. / max. allowable pressure	4 / 16 bar
Sound pressure level (free-field measurement in distance of 1.5m)	up to 80 dB (A)
Min. / max. temperature	+4 to max. 45 °C



According to the definition in the pressure equipment directive, pressure vessels are not subject to repeated tests. If necessary, regional or national specifications can be applied in addition or as supplementary. The adsorption dryers are inspection-free, according to the definition of the pressure equipment directive.

3. Safety notes

The DRYBERG® AD adsorption dryers have been built according to state-of-the-art technology and the latest safety regulations. However, there is still a risk of danger during operation, maintenance, installation, servicing and during transport and setup. In particular, ignoring the safety regulations when handling compressed air may result in serious injury or death. Therefore only expertly trained personnel in safety should operate this unit.



- Observe the safety notes in this manual and on the adsorption dryer.
- Observe all safety notes, even those in the individual chapters.
- Observe all legal guidelines and safety regulations (it may vary from region to region!)
- Observe all local site regulations which are stipulated for the field of application.

3.1 Signs and symbols

The following sign can be found on the adsorption dryer:

- **Type plate** (on the right side of the vessel)
It shows details of the type, year of manufacture, serial number of the device, performance data, weight and filters installed.

Typ / Type	max. Druck / max. Pressure
S-Nr. / S-No.	Spannung / Voltage
Leistung / Capacity	Vorfilter / Prefilter
m ³ /h bei / at bar g	Nachfilter / Final filter
Baujahr / Built	
Gewicht / Weight (kg)	CE
kg	Made in Germany
Vor Inbetriebnahme und Service das Handbuch lesen. Read the manual before operation and service.	Gefahr durch Druckluft! Danger Compressed air!

The type plates on the unit show important information. Please make sure that they are always readable and that they can be accessed.

3.2 Danger zones

Risk due to pressure-containing parts



Risk of slipping due to spilt desiccant on the floor

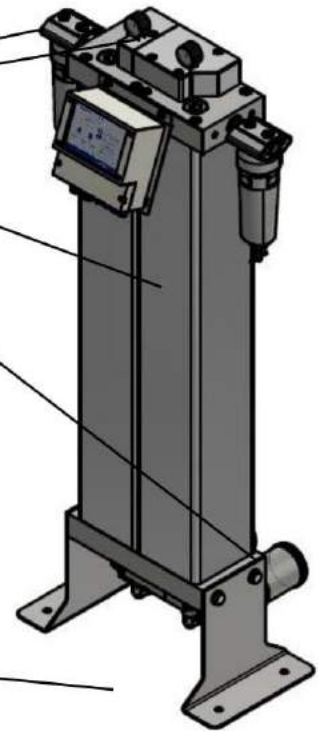

- Never operate the adsorption dryer exiting the design conditions shown on the vessel plate.
- Never carry out maintenance work as long as the adsorption dryer is under pressure.



- Do not modify the structure of the adsorption dryer or change its function.
- Only use the adsorption dryer for its intended purpose.
- Do not climb onto the adsorption dryer.



- Do not carry out welding work on pressure-containing parts.
- Wear breathing protection and eye protection when changing the desiccant.



- Risk of slipping due to spilt desiccant.
- Always check that the silencers are securely installed and wear eye protection.



- Never operate the adsorption dryer if there is apparent damage.
- Avoid sparks and open flames especially during desiccant change.
- Never use parts of the equipment to lift up the adsorption dryer, always exclusively use its base sections and profiles.
- Only carry out maintenance work on the adsorption dryer if it has been disconnected from the power supply.

Desiccant

The desiccant used does not belong to the hazardous substances group and are therefore not subject to labelling requirements. Nevertheless, please observe all common safety measures with regard to using chemicals. Please also wear your personal protective equipment (safety glasses and breathing protection). Please also note that the desiccant material accumulates contaminants including oil vapour parts. This can cause additional dangers.

If you require further information, contact the manufacturer to receive a copy of the safety data sheet of the desiccant.

4. Technical product data

4.1 Equipment overview, front view

- 1 - Pre filter
- 2 - Final filter
- 3 - Control unit
- 4 - Pressure gauge
- 5- Piston block top
- 6- Bottom plate
- 7- Piston block bottom
- 8- Solenoid valve for pressure release and process
- 9- Silencer
- 10-Inlet
- 11-Outlet
- 12-Condensate float drain pre filter

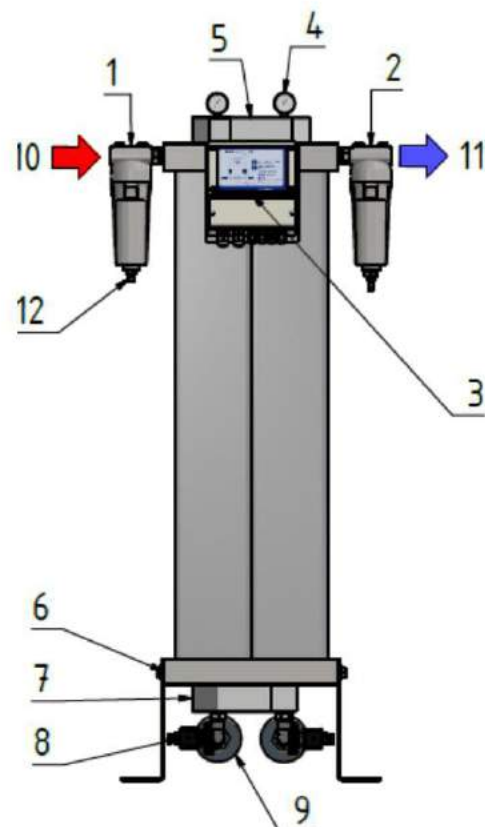

4.2 Equipment overview, rear view

1. Pre filter
2. Silencer
3. Shuttle valve block bottom
4. Solenoid valve
5. Manual drain final filter
6. Condensate float drain
7. Final filter
8. Pressure gauge
9. Shuttle valve block top
10. Silencer
11. Inlet
12. Outlet

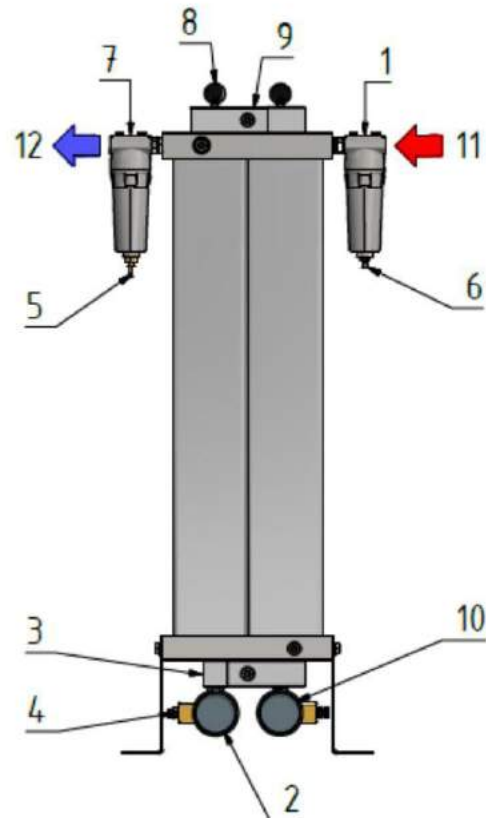

4.3 Function description



Moisture is stored in the large, open pores of the desiccant, thus reducing the moisture content in the compressed air.

Through the joining pipe, the compressed air is led via the inlet into the diffuser sieve type (flow distributor). The compressed air is hereby equally distributed through the vessel cross-section for optimized efficiency. Based on the laws of physics and the calculated required contact time, the moisture of compressed air is adsorbed by the pores of the desiccant. The dried compressed air then leaves the vessel again via a diffuser on the outlet.

The compressed air inlet temperature is important for the performance of the adsorption process. High inlet temperatures reduce the performance of the desiccant since heat of adsorption is generated depending on the moisture to be adsorbed. It can exceed a critical level if the inlet temperature is too high (usually $> 55\text{ }^{\circ}\text{C}$) and desiccant starts to release moisture instead of adsorbing moisture.

The moisture stored gradually saturates the desiccant. By the defined cycle time of the adsorption phase, the desiccant bed is optimally used. After a determined time the desiccant is regenerated again following the counter-flow

principle using the dried compressed air, which is taken from the dry output flow through an orifice. This process constantly switches between the two vessels. Depending on compressed air quality at the inlet, it is possible to achieve a service life time of the desiccant of much more than 10,000 hours.

Operating principle:

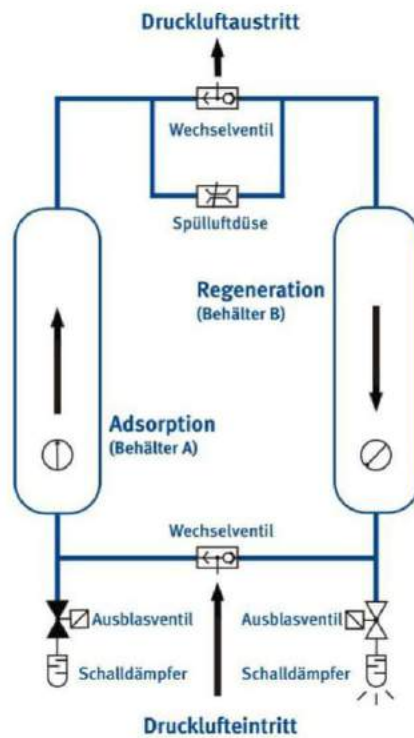

5. Monitoring the operation

The following equipment is available for regular monitoring:

The pressure gauges display the operating pressure. They provide information about the regular switch-over of the adsorption dryer.



The control unit EVERMATIC uses LEDs to display the status of the adsorption dryer.

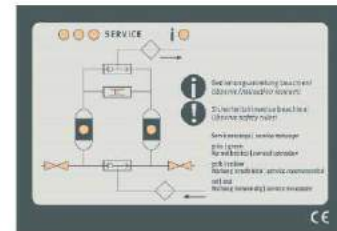

If a dewpoint controller is used, then the operating status is also shown. Note: The controller has to be changed to controller type EVERMATIC "LDC".

When daily checks are carried out, observe the noises which are caused by the regeneration process. The pressure gauges should also be observed. The expansion and noises of the purging air should always be regular. Interruptions in the flow noises could indicate a defective solenoid valve or control fault.

6. Transport, storage and setup

6.1 Transport

i Although great care is taken, please check immediately whether the adsorption dryer has been damaged in any way. Any kind of transportation damage must be communicated immediately to the manufacturer and recorded on the delivery note.

- Suitable hoisting equipment must be used for the transportation, loading and unloading process.
- The device must only be lifted at the designated points: crane hook or transport pallet.

- Take the weight of the adsorption dryer into account and use suitable lifting equipment.
- Do not remove the packaging until the device is moved to its place of installation.
- Only appropriately qualified personnel may carry out the transportation.
- Apply all regulations of safety instructions.

6.2 Storage



If the adsorption dryer needs to be stored before being installed, ensure that the site of storage fulfils the following requirements:

- Indoor
- Dry
- Freezing-free
- Protected from weather.



If the device has to be stored after having been used, please proceed as follows:

- Depressurise the adsorption dryer.
- Disconnect the adsorption dryer from the compressed air system.
- Close the compressed air inlet and outlet by plugs.

6.3 Setup



Please refer to the setup conditions described in Section 2.1. The basic data required for the setup can be found in the performance data in Section 2.2.

When setting up, make sure

- that the ground is even and capable for carrying the weight.
- there is enough space around the adsorption dryer to carry out the servicing and maintenance work. We recommend at least 0.8 m.
- that the adsorption dryer can be reached and accessed by the lifting devices.
- the adsorption dryer is operated by skilled staff only and safety signs should be affixed for non skilled staff.
- the adsorption dryer cannot be hit by haulage vehicles.
- the safety signs are clearly visible at all times.

There are mounting holes in the base frame of the adsorption dryer. These should be used to fix the device to the ground.

7. Installation

7.1 Recommendations for installation



Proper installation is the basic condition for the safe and trouble-free operation of the DRYBERG® AD series.

We recommend the installation of shut-off devices both side upstream and downstream of the adsorption dryer. So the adsorption dryer can easily be disconnected from the compressed air system during maintenance.

If operation cannot be interrupted during maintenance, a by-pass line must be provided. It should at least include a filter combination MF and SMF to prevent a contamination of moisture in liquid form downstream of the adsorption dryer.



We recommend installation after a corresponding pretreatment. At least a water separators should be already installed upstream to prevent overload of the prefilter, which is part of the system. The adsorption dryer is usually installed behind a receiver tank.

The pre filter with a separation degree of 0.1 μ is installed at the inlet of the adsorption dryer (included in the delivery) to collect any possible additional liquid drops, oil mist and particles, which would otherwise block the pores of the desiccant for the drying process.

Installing the adsorption dryer behind a receiver tank also has the advantage that pulsating compressed air is buffered and the temperature at the inlet of the adsorption dryer is cooled in the receiver tank. Make sure the compressed air inlet temperature is as low as possible and all condensate is removed. This then increases the service life of the desiccant and the adsorption dryer works most efficiently.

When installing a receiver, make sure that

- there is no reverse flow (e.g. install a non-return valve).
- the compressed air inlet temperature does not exceed the maximum permissible value.
- pressure shocks or pulsating compressed air are buffered by a receiver tank.
- The condensate separation works properly.

7.2 Demands on the installation

Prior to installation, check the following:



- The compressed air system and the adsorption dryer must be pressure released.
- For compressed air systems which need to remain under pressure, shut-off devices have to be protected against unintentional opening.
- The operating pressure in the system cannot be higher than the maximum permissible operating pressure of the adsorption dryer (Check the setting of the pressure of the pressure relief valves of the system).
- There must be no pressure surges in the system causing damage to the desiccant (e.g. from valves which open abruptly).
- The pipelines are designed for the operating pressure and the flow rate of compressed air.
- Vibration transmission or vibration are avoided.
- Nothing left in the pipeline from installation and welding process.

7.3 Elimination of hazards

Prior to installation, check the following:



- Do not work on parts which are pressurized.
- The pipelines must held in place by brackets; the adsorption dryer is not designed to be used as a support for the pipes.
- The adsorption dryer must only be used in the defined operating conditions (see vessel plate), it is the duty of the operator to observe these values.

8. Commissioning



All work on DRYBERG® AD adsorption dryers and on the pipe and drainage systems must only be carried out by trained and experienced persons.

8.1 Commissioning requirements

The following must be checked prior to commissioning:



- The maximum operating conditions must not be exceeded.
- Upstream and downstream shut-off devices are closed.
- All connections are securely tightened.
- Complete visual check. Do not use the adsorption dryer if it is damaged in any way.

8.2 Pressurisation



If section 8.1 is checked successfully, the following steps can be processed sequentially.



Wear ear protection for this, as the flow noise can get very loud.

1. Make sure that the compressed air system is under pressure upstream of the adsorber.
2. Slowly open the shut-off valve upstream of the adsorption dryer until you hear the flow noise.
3. Keep an eye on the pressure gauge on the vessel. Pressure must rise slowly.
4. At 4 bar, close the shut-off device again at the inlet. Check all connections for leaks. If leaks are found, the adsorption dryer must be depressurized again and the leaks must be eliminated.
5. If no further flow noises can be heard and if the pressure gauge does not indicate any further increase in pressure, the shut-off valve can be opened completely.

8.3 System operation

After pressurisation has been successfully completed, check whether the compressed air system downstream of the adsorption dryer can be opened safely.

Then proceed as follows:

1. Slowly open the shut-off valve at the outlet of the adsorption dryer until you hear the flow noise.
2. Keep an eye on the pressure gauges. Should the pressure suddenly drop, check whether any tapping points are still open.
3. If the pressure remains stable and the flow noise has stopped, the shut-off valve downstream of the adsorption dryer can be opened completely.
4. Start the controller. Once switched on, it can take 1 minute until the first valve is opened.
5. Keep an eye on the pressure gauges. The operating pressure must be virtually "0" on the regenerating side. The expansion noise is loud, only flow noises should be perceived after this.
6. Once regeneration has been completed, pressurisation starts. During this process, the previously opened valve must be closed and pressurisation must start again.
7. Once the pressurisation time has passed, the pressure on both vessels must be virtually the same.
8. Now also take into account the expansion (regeneration) on the other side. If this also works as described above, the adsorption dryer is ready for operation.



8.4 Disconnecting from the system



Should you have to disconnect the adsorption dryer from the system, e.g. for maintenance work, make sure that this work is only carried out when the system is pressure released.



Wear your safety equipment. Proceed as follows:



1. Close the shut-off valves at the inlet and outlet of the adsorption dryer.
2. Switch off the controller.
3. Open the manual drain on the after-filter housing.

Manual drain



4. Keep an eye on the pressure gauges and wait until both displays "0" bar before starting work.

9. Maintenance

Maintenance work may only be carried out by qualified personnel! Make sure that the device is pressure released before starting work and observe the safety regulations applicable at the place of installation!

9.1 Regular maintenance work

The following table gives an overview of the intervals and scope of the maintenance work:

Maintenance of	Activity	Every day	Every month	Every 12 months	Every 24 months	Every 48 months
Pressure gauge and controller	Visual check, functional check	X				
Control box	Check that the cables and terminals are securely fixed			X		
Silencer	Clean			X		
	Replace				X	
Pre and final filter element	Replace the filter element			X		
Desiccant	Replace					X
O-rings of filter housing	Replace				X	
Piston	Replace				X	
Solenoid valves	Replace				X	
Pressure dew point sensor (if installed)	Recalibrate				X	

9.2 Daily checks

The following should be checked every day:

- The pressure difference (pressure drop) upstream and downstream of the adsorption dryer is not more than 0.5 bar.
- Open the manual drain slightly on the after-filter. It must not drip any water.
- Check if you can hear any unusual noises.
- Check for leaks.
- Check that the condensate drain of the pre filter works properly.

9.3 Checking the pressure dew point

If a pressure dew point controller is installed, the pressure dewpoint is also displayed. You can then set the pressure dew point according to your requirements.

With the standard package, the EVERMATIC (time control only) is already installed. Since this controller can't measure the pressure dewpoint, you should measure it externally from time to time.

Determine a measuring point behind the dryer and connect an external measuring device. Make sure that this measurement is used in accordance with the manufacturer specifications and that it is suitable for the pressure dew point range of the adsorption dryer. Record these values in order to be able to track performance of the dryer.

9.4 Overview of maintenance parts

9.4.1 Annual maintenance

The following maintenance parts should be replaced every 12 months:

Type	Component	Description	Qty	Interval	Measure
AD20	EF 04 / 18	Filter element	1	12 months	Replace
AD35	EF 04 / 18	Filter element	1	12 months	Replace
AD50	EF 04 / 18	Filter element	1	12 months	Replace
AD70	EF 05 / 18	Filter element	1	12 months	Replace
AD90	EF 05 / 18	Filter element	1	12 months	Replace
AD110	EF 05 / 26	Filter element	1	12 months	Replace

9.4.2 Two- and four-year maintenance

The following maintenance parts should be replaced every 24 / 48 months:

Type	Component	Description	Quantity	Interval	Measure
AD20	KIT-AD20	Functional components set	1	Every 24 months	Replace
	AM-AD20	Desiccant filling	1	Every 48 months/ when required	Replace
AD35	KIT-AD35	Functional components set	1	Every 24 months	Replace
	AM-AD35	Desiccant filling	1	Every 48 months/ when required	Replace
AD50	KIT-AD50	Functional components set	1	Every 24 months	Replace
	AM-AD50	Desiccant filling	1	Every 48 months/ when required	Replace
AD70	KIT-AD70	Functional components set	1	Every 24 months	Replace
	AM-AD70	Desiccant filling	1	Every 48 months/ when required	Replace
AD90	KIT-AD90	Functional components set	1	Every 24 months	Replace
	AM-AD90	Desiccant filling	1	Every 48 months/ when required	Replace
AD110	KIT-AD110	Functional components set	1	Every 24 months	Replace
	AM-AD110	Desiccant filling	1	Every 48 months/ when required	Replace

9.4.3 Two-year maintenance / Tighten the screws

Due to the fact that DRYBERG® AD dryers use the pressure swing process at least every 2 years the screws should be controlled. Please tighten the screws exclusively with a torque wrench. Check all screws on the top and bottom plate!

DRYBERG® AD 20		22,5 Nm
DRYBERG® AD 35 ... 50		44,0 Nm
DRYBERG® AD 70 ... 110		74,0 Nm



9.5 Replacing the filter elements

The prefilter of the adsorption dryer retains particles and liquid forms of oil and water, thereby protecting the desiccant against contamination. The after-filter removes any abrasion dust that has been generated from the desiccant. Proceed as follows to replace these filter elements:

1. Close the shut-off valves upstream and downstream of the adsorption dryer.
2. Open the manual drain on the filter in order to release the pressure and wait until the pressure gauges on the adsorption dryer show "0" bar.
3. Turn the bottom part of the filter housing (filterbed) in clockwise direction to open it. Unscrew it completely and put it down carefully.
4. Now you can remove the filter element from the filter.
5. Use a damp cloth to clean the inside of the filter housing.
6. Check whether the O-ring in the filter head is OK. Replace it if necessary.
7. Please fit the new filter element into the three pockets at the filter head, inside of the filter bowl.
8. Screw the filter bed back and close the manual drain.
9. Slowly open the shut-off device at the inlet and check the system for leaks.
10. Once the pressure is back to normal again, slowly open the shut-off device at the outlet.

9.6 Replacing the desiccant

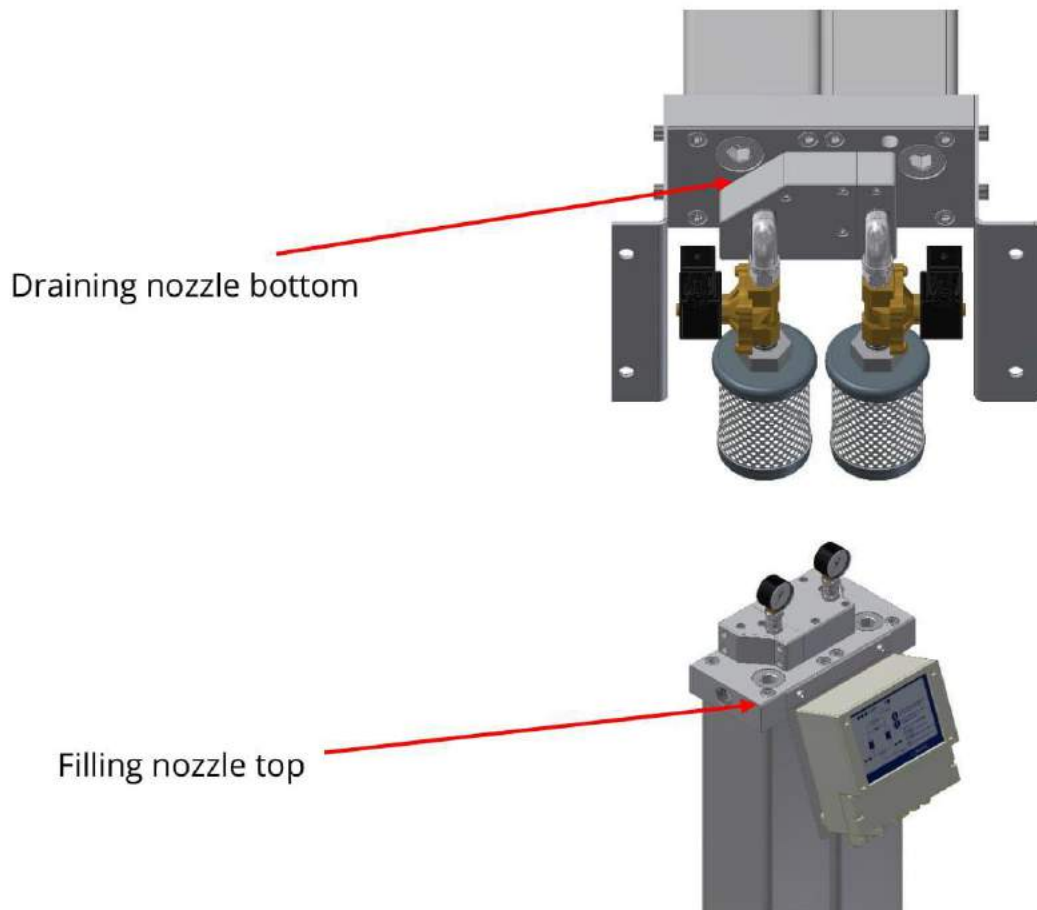

When replacing the desiccant, make sure to wear your safety equipment, especially the breathing protection and safety glasses.

There is high risk of slipping if material is spilt!



The service life of the desiccant is mainly depending on the quality of the compressed air at the inlet of the adsorption dryer. Strain from oil vapour reduces the service life significantly. In favourable conditions the service life time can reach much more than 10,000 hours. Proceed as follows to replace the desiccant:



1. Depressurise the adsorption dryer.
2. Open the filling plug on the top.
3. Place a bucket underneath the bottom draining plug and remove it also.
4. Collect the desiccant as it drains off.
5. Empty the vessel completely. (you can also empty the vessel using a vacuum cleaner).
6. Clean the diffusors inside the vessel.

7. Close bottom draining plug again and fill the new desiccant through the top filling opening. Depending on the application, the desiccant can consist of several layers. Make sure that the desiccant is filled in the correct order. WS and alumina materials generally form the water protective layer and must be filled first.
8. Once you've reached the filling opening, concentrate the desiccant by slight vibration of the body of the adsorption dryer and then top up again until the desiccant no longer compressible.
9. Screw the top filling plug again.



We recommend to change the filter element of the dustfilter two weeks after the desiccant change. Change or at least clean the solenoid valves after a 2 weeks trial run. The dust particles that accumulate during the trial run are captured in the after-filter element. Replace the filter element after the trial run.

The adsorption dryer needs several cycles before it reaches the desired pressure dew point. Take into account that the piping system behind the adsorption dryer may become contaminated with moisture during the start-up phase. You may need to provide a blow-off line for the start-up.



Contaminated desiccant must be disposed in accordance with the local law and regulations!

The disposal code for "Used, non-contaminated desiccant": 06 08 99!

If other toxic or hazardous substances have been stored, this must be determined by the operator and the desiccant must be disposed of taking the type of contamination into consideration!

9.7 Shuttle valve piston replacement

The shuttle valve pistons in DRYBERG® AD dryers are installed in the top and bottom plates. The pistons suffer from mechanical stress so they need to be replaced every 2 years. To exchange them, please follow the following procedure:

1. Depressurise the adsorption dryer.
2. Make sure that the pressure gauges show "0" and that the adsorption dryer is fully depressurised.
3. Switch off the control device.

4. Loosen the top screws first.
Make sure that nothing can get into the opening.

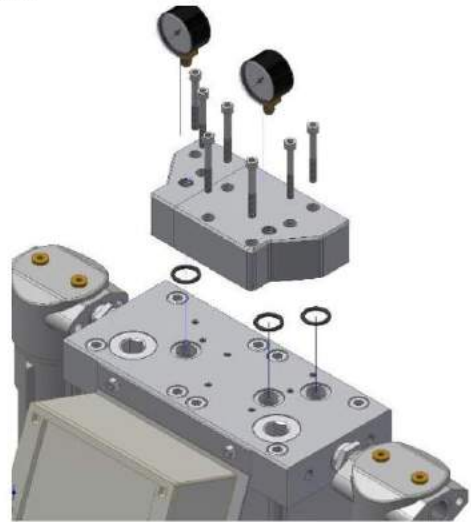

5. Remove the screws on the side and exchange the piston.
(ATTENTION! The piston with an integrated orifice needs to be installed on top)

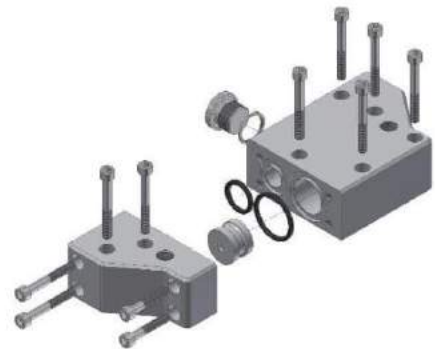

6. The socket on the back side of the piston block can stay closed.
Replace the o-rings, too, and remount the block onto the plate.
Grease the screws before mounting.

7. Remove the solenoids from the valves. Afterwards you can disassemble the block completely and dismantle the silencers and solenoid valves.

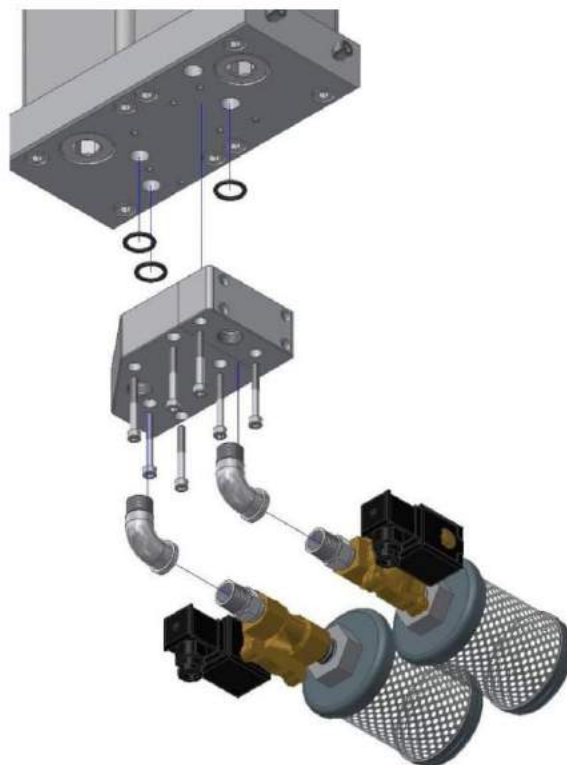

8. Then, remove the screws on the side of the block, too. Exchange the piston and the o-rings. Reassemble the block and fix it below the plate.
9. Fix the solenoid valves and the silencers again and attach the solenoids to the valves.
Open the shut-down valves in front of the dryer slowly and check for leakages by rising the pressure up to 4 bar. Open the valves completely if there are no more leakages.



ATTENTION!

When assembling the block again please take care that the tightening torque of the screws is not higher than max. 7 Nm (DRYBERG® AD 020); max. 12 Nm (DRYBERG® AD035 ... 060); max. 23 Nm (DRYBERG® AD070 ... 110)

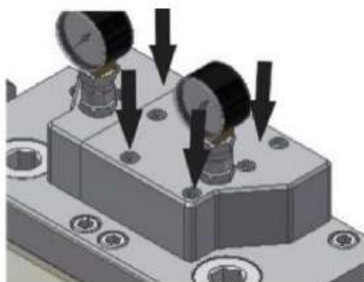

9.8 Replacing the solenoid valves

The solenoid valves are supplied fully assembled and should also be replaced as such. These valves are also subject to a mechanical force and must be replaced after two years. Proceed as follows to replace them:

1. Depressurise the adsorption dryer.
2. Make sure that the pressure gauges show "0" and that the adsorption dryer is fully depressurised.
3. Switch off the controller by disconnecting the mains power plug.
4. Loosen the solenoid valve plug.
5. Loosen the screw connections.
6. Remove the exhaust piping and silencers.
7. Dismantle and replace the solenoid valves.
8. Fit the exhaust piping and silencers back. Tighten all screw connections again.

1. bottom plate
2. removable connection
3. solenoid valve plug
4. solenoid valve
5. silencer
6. desiccant discharge nozzle
7. bottom shuttle valve block

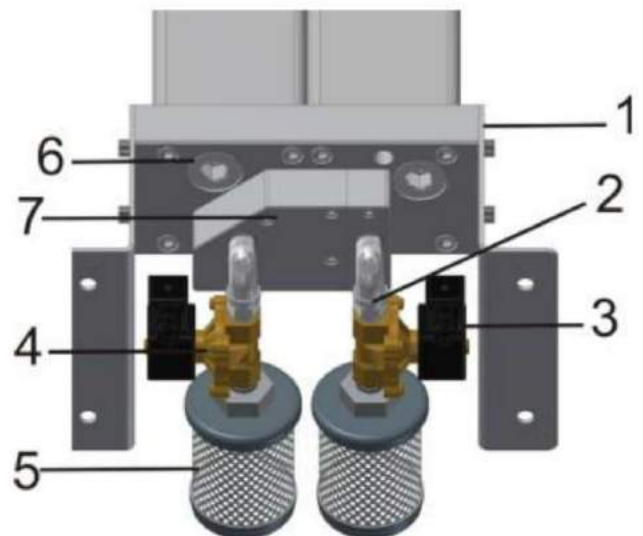

9.9 Replacing the silencers

The silencers reduce the noise generated by the pressure release and regeneration process. These silencers are usually polutate by desiccant abrasion in the form of dust. Combined with the outgoing moist air the silencers become clogged after a while and must be replaced. Proceed as follows to replace them:

1. This work must only be carried out after the device has been depressurised.
2. To do so, close the inlet and outlet shut-off devices.
3. Switch off the controller by disconnecting the mains power plug.
4. Unscrew the silencers from the threads in counterclockwise direction.
5. Wrap a few layers of teflon around the thread of the new silencer to make it easier to dismantle it later on. Then screw the new silencer back in again in a clockwise direction until it is hand-tight.
6. If the desiccant also has to be replaced, replace it first before replacing the the silencers after a 2 weeks trial run.

Disassembly

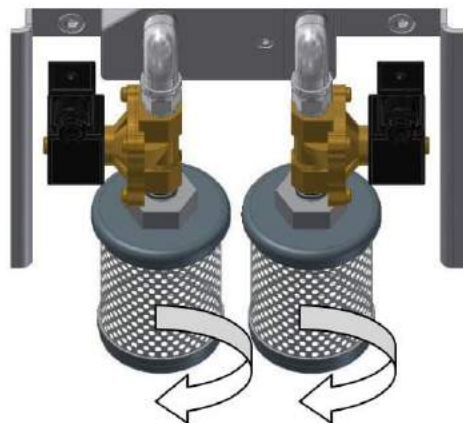

Assembly

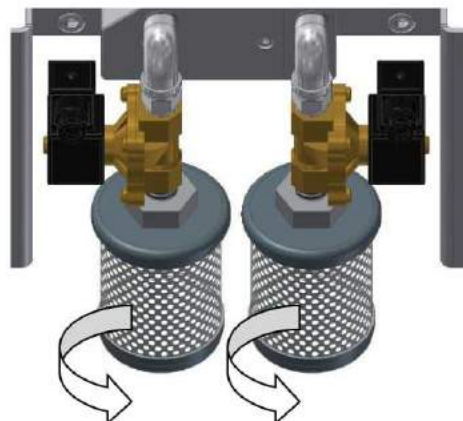

10. Replacing the dew point sensor

If you've chosen the "LDC" option (Load dependent control system), you must replace the sensor every two years. The sensor element must be replaced as follows:

The work must only be carried out after the device has been depressurised.

1. To do so close the inlet and outlet shut-off devices.
2. Switch off the controller by disconnecting the mains power plug.
3. Loosen the cubical plug of the sensor element.
4. Unscrew the sensor element in the counter-clockwise direction.
5. Fit the new sensor element by screwing it in the clockwise direction.
6. Screw the cubical plug back onto the sensor.
7. Slowly open the inlet shut-off device until both vessels are pressurised again.
8. Check for leaks on the screw connection. If there is a leak, seal it.
9. Then start up the controller and open the shut-off device on the outlet.

Sensor in outlet pipe

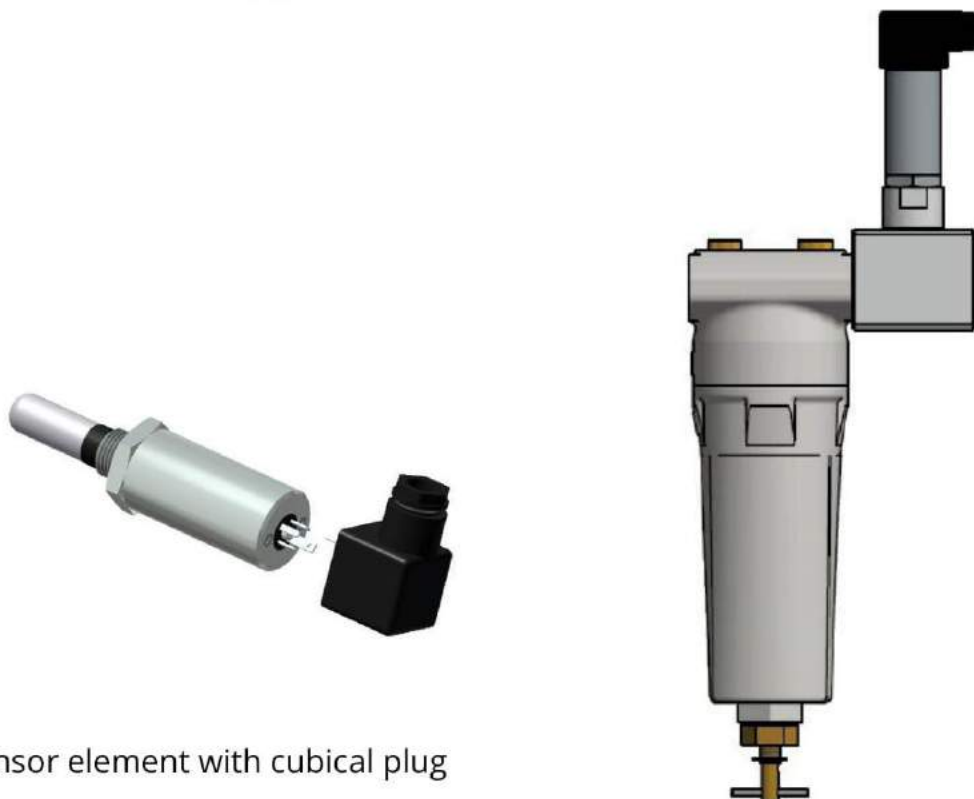

Sensor element with cubical plug

11. Faults

The following faults may occur:

Error	Possible cause	Corrective action
Device does not switch on	No power supply	Check supply voltage
	fuse defective	Replace fuse
Dryer does not regenerate	Controller does not work	Call service
	No power supply	Check supply voltage
	Compressor synchronisation circuit is active	Set DIL switch No. 8 to "1" (for EVERMATIC)
	Solenoid valve does not open	Check cable connection / terminals
Replace magnetic coil if necessary		
Dryer does not reach the pressure dewpoint	Desiccant not sufficiently regenerated	Allow it to keep running (after 48 hours at the latest, the pressure dewpoint should be reached)
	Water / oil breakthrough	Call Maintenance, replace desiccant if necessary
	Defective condensate drain	Check prefilter
	Inlet conditions incorrect (pressure, temperature)	Call service
	Compressed air extremely undersaturated	Call service
	Check input parameters, possible by-pass buildup in the desiccant due to flow rate being too low	Call service
	Silencer blocked	Replace silencer
No pressure indicated on pressure gauge of dryer	Inlet to dryer closed	Open the supply line
Differential pressure indicator is in red zone	Filter element is clogged	Replace filter element

Dryer keeps turning to alarm status	Reverse flow through by-pass	Change by-pass, install nonreturn valve, call service
Compressors start up too frequently	Leakages	Call service
No pressurisation	Piston in undefined position	Switch off controller, allow pressurisation to take place, then switch controller back on again

13. EU Declaration of conformity

EU Declaration of conformity

We, the manufacturer,
BERG KOMPRESSOREN GmbH



hereby declare that for the systems listed below:
Adsorption dryer DRYBERG® AD20 to AD110

the harmonised standards:
DIN EN ISO 12100-1-2; DIN EN ISO 14121-1; DIN EN 55011; DIN EN 61000-6-2,
61000-3-2, 61000-3-3 have been adhered to.

The conformity assessment procedure was completed in accordance with Module A.

The pressure vessels which are part of these assemblies have been manufactured in construction and design conforming to the European Guideline 2014/68/EU Appendix I for pressure equipment as per the technical rules of the AD2000 instruction sheets.

Any modifications made to the equipment which has not been approved by the manufacturer will result in cancelation of this declaration.

Krefeld, 01.09.2023

Signed:

Martin Safari,
Managing Director
BERG Kompressoren GmbH

