



BERG Kompressoren GmbH
Compressed Air Technology | Air Separation

OPERATING AND MAINTENANCE MANUAL

Screw compressors

KOMPBERG

PART I

01.2024



Ladies and Gentlemen,

We heartily welcome you among our valued Customers and thank you for your trust to purchase the BERG compressor.

We are sure you will be fully satisfied with both the choice you have made and the cooperation you started with us. Our compressors are machines of top quality, which is the guarantee for a long years and reliable performance.

Our sales and service staff is available to answer all your queries regarding the installation and operation of your compressor. You are also encouraged to use our warranty and post-warranty technical service.

1. Information concerning the document.....	4
1.1. Scope and intended use of the manual	4
1.2. Intended use of the compressor and conditions of safe use	4
1.3. Qualification requirements for operation of the compressor.	5
1.4. Operation	5
1.5. Other remarks and instructions	6
1.6. Warranty	6
2. Operating safety rules	6
2.1. Basic requirements for safe transport and positioning of the screw compressor	7
2.2. Operating safety requirements	8
2.3. Other hazards	8
2.4. Meaning of pictograms	9
3. Identification plate	9
4. Setting	9
4.1. Room requirements	9
4.2. Requirements concerning electrical system	10
4.3. Compressed air connection	11
4.4. Compressed air treatment	12
5. Operation description	13
5.1. Screw compressors operation description	13
5.2. Screw compressors with inverter operation description	14
5.3. ULTRA SPEED function – in compressors with motor power of 5.5 - 90 kW and inverter	15
6. Start-up.....	15
6.1. Start-up preparation.....	15
6.2. Restart (after longer downtime)	16
7. Procedure in case of compressor self-deactivation or shutdown by using the emergency stop. ...	16
8. Maintenance.....	17
8.1 General requirements	17
8.2. Maintenance and inspections	18
8.2.1. Maintenance at the beginning of the compressor use and after oil and V-belts (where applicable) change	18
8.2.2 Daily maintenance	18
8.2.3 Periodic maintenance	18
8.2.4 Warranty and post-warranty inspections	19
8.2.5 General remarks	20
8.3 Basic components requiring maintenance and descriptions of maintenance operations. ...	21
8.3.1. Air filter cartridge	21
8.3.2. Filter mat	22
8.3.3. Oil filter	23
8.3.4. Oil separator	23
8.3.5. Oil level	25
8.3.6. Water condensate draining.....	25
8.3.7. Oil change and recommendations concerning oil.....	26
8.3.8. Handling wastes produced while operating the compressors	27
8.3.9 Pressure switch.....	27
8.3.10 Oil temperature gauge (where applicable)	27
8.3.11. Oil cooler / air cooler	27
8.3.12. Electric motor	28
8.3.14. Safety valve	28
8.3.15 Radial / axial fan	30
9. Troubleshooting.....	32

PART II

- Technical data
- Screw compressor drawings (compressor components layout and dimensions)
- Consumables
- Electric diagram
- Controller operating manual

1. Information concerning the document

This operating and maintenance manual is an integral part of the machine. It includes the information necessary to start, operate and maintain the compressor and requirements for its safe operation.

Following the manual rules will help you:

- Avoid hazards,
- Reduce repair costs and downtime,
- Increase the machine reliability and life.

Getting familiar with this manual in detail, using the machine in accordance with descriptions included in it and following all safety conditions are the basis for correct and safe operation of the machine.

In addition to the operating and maintenance manual and the regulations applied in the country of destination and health and safety at work regulations applied locally at the workstation, the generally recognised technical rules for safe and correct work are also valid.

1.1. Scope and intended use of the manual

The operating and maintenance manual is intended for qualified / suitably trained operating personnel of the compressor. The personnel assigned to operation of the compressor must, before starting work, get familiar with the manual contents, in particular the “Health and safety at work regulations” section.

The manual includes

- Description of daily service and maintenance of the compressor and control system,
- Technical documentation of the electrical part. It includes the data necessary to perform correct connections and repairs of the electrical equipment,
- Technical documentation of the mechanical part. It includes the data necessary to perform repairs of the mechanical equipment,
- Technical documentation of the control system. It includes the data necessary to switch on and off, and set operating parameters of the compressor.

The qualified personnel is understood to be the persons who because of received training, experience and knowledge of important standards, documentation and regulations concerning safety and operating conditions were authorised to carry out necessary operations and are able to recognise and avoid possible hazards.

1.2. Intended use of the compressor and conditions of safe use

The compressor is designed to produce only compressed air. It should be installed in accordance with the stipulations concerning the compressor installation and connection. The compressor must not be used for any other purposes that are non-compliant with its intended use. The manufacturer shall not be liable for any damage resulting from that reason. In that case, the risk is born by the machine user only.

During the compressor operation, you must follow the procedures given in the “Maintenance” section as regards scope and frequency of maintenance work and materials to be used.

Warning about forbidden use

- The compressor must not be used for any other purposes that are non-compliant with its intended use.
- Under no circumstances must the limit operating parameters of the compressor be exceeded and changed - refer to section 10 "Technical data".
- To use it for compression of other gases than air, it is required to obtain the manufacturer's consent. The above consent must be in written form.
- The compressor must not be used in potentially explosive atmospheres within the meaning of Directive 2014/34/EU.
- The compressor must not suck any toxic, acid-containing, flammable or explosive gases and vapours.
- Never direct a jet of compressed air at people or animals.

Safe use of the compressor

- The compressor must be operated in accordance with all guidelines included in this operating and maintenance manual.
- The sucked air must be clean and must not contain any harmful substances.
- The heated cooling air may be used for heating purposes if only its harmfulness to people and animals is excluded. Otherwise, it is necessary to provide the appropriate treatment of cooling air.
- Compressed air may only be used for breathing after its appropriate treatment.
- Compressed air not subjected to the appropriate treatment must not be used in production processes in which there is contact of air with food.



The compressor delivered is designed to compress only air. To use it for compression of other gases, it is required to obtain the manufacturer's consent. The above consent must be in written form. The compressor must not be used for any other purposes that are non-compliant with its intended use.



Fulfil the obligation to register the compressor air receiver in the Office of Technical Inspection (UDT). The compressor documentation is accompanied by the set of the required documentation of the air receiver (if applicable) and safety valve.

1.3. Qualification requirements for operation of the compressor.

The personnel who installs, operates and maintains the compressor should have the appropriate education and qualifications enabling safe operation of electrotechnical and electrical equipment.

Installation, operation and maintenance of the compressor may only be carried out by the persons who are familiar with this operating and maintenance manual, follow instructions included in it, know safety regulations and recognised technical rules.

1.4. Operation

While operating the compressor:

- Observe the instructions provided in the Operating and Maintenance Manual and Warranty Book.
- Follow the periodic inspection schedule during both warranty period and after its completion. Regular performance of periodic inspections is necessary to ensure the required reliability and life of the BERG equipment. The inspections performed according to the schedule reduce the number of repairs and their cost.
- The technical and operating inspections should be carried out in accordance with the schedule and conditions by the factory service or authorised service, using the manufacturer's consumables and spare parts.
- During the warranty period, use only the manufacturer's consumables and spare parts.



The detailed list of maintenance operations can be found in the "Maintenance and inspections" section.

1.5. Other remarks and instructions

- This Operating and Maintenance Manual provides all information on how to install, start and operate the compressor. This manual should also be used when any maintenance work is carried out,
- The Manual should be read and always available to the compressor operator,
- During the maintenance work and periodic inspections, the provisions of the Warranty Book should be observed,
- The Maintenance section provides all measures and requirements necessary to keep the compressor in a correct technical state,
- Record all operating data, maintenance operations performed etc. into the Warranty Book. Observe all reference and local safety regulations relating to the compressor, including those listed herein and in the following sections,
- Failure to follow the requirements included in this Operating and Maintenance Manual and Warranty Book and/or unauthorised changes in the compressor or its integral units delivered by us shall make the warranty null and void.
- During warranty period, any repairs must be performed by the manufacturer service or authorised service centre listed in the Warranty Book.

1.6. Warranty

BERG KOMPRESSOREN GmbH hereinafter referred to as the Warrantor provides the warranty for the products sold, ensures correct operation of the offered products provided that they are used in accordance with their intended use and operating conditions specified in this documentation.

The Purchaser shall lose its warranty rights for the product when:

- The machine is used in a way non-compliant with its intended use,
- Unauthorised modifications are carried out on the product,
- Interventions are carried out by unauthorised persons,
- Any repair attempts are carried out by unauthorised persons,
- The obligation to carry out periodic inspections is not observed,
- Non-original consumables are used.



The manufacturer reserves the right to make modifications in the product, resulting from continuous technical development, without prior notice.

2. Operating safety rules

The present rules are valid for BERG screw compressors. In addition to the general health and safety at work and the Office of Technical Inspection (UDT) regulations applicable to compressors, their assemblies and accessories, the safety instructions given below should be followed in particular. The operators are supposed to observe safe work practices. It is the user's responsibility to continuously maintain the compressor fully operable. Components and equipment considered to be no longer suitable for safe operation should be promptly replaced. Adjustments, installation, operation, maintenance and servicing should be entrusted only to properly trained, qualified and authorized staff. The limit values (pressure, temperature, time settings etc.) are given in the Technical Data section.



The limit values may not be changed by the user.

The manufacturer accepts no responsibility for any personal injuries, damage of equipment or the compressor itself, at present and in the future, resulting from user's negligence and failure to observe the installation, operation and maintenance requirements contained herein. No responsibility is also taken for failure to observe valid safety standards relating to the equipment and qualified staff.

2.1. Basic requirements for safe transport and positioning of the screw compressor

In addition to the general health and safety at work and the Office of Technical Inspection (UDT) regulations, the following rules must be observed:

- Use only the lifting equipment that is compliant with the H&S and UDT regulations to lift the compressor. Fix in place all rotating or loose parts of the machine before its lifting. It is strictly forbidden to stay in the hazardous zone of the lifting equipment operation. The compressor movement can be accelerated or slowed down only within the permissible limits.
- When the compressor is transported, the transport straps should be pulled under the machine and secured above the housing in such a way that they do not place pressure on it. If the transport harness is fastened and secured incorrectly, the machine may get damaged.
- If the compressor is transported on wooden pallets, it should be secured against movement during transport. Fasten the compressor frame with cargo straps to appropriate holders on the vehicle platform to prevent it from sliding or overturning.
- All screw and pipe connections should be of appropriate size and designed for a given operating pressure.
- The compressor is not designed to operate outdoors; it cannot be exposed to weather conditions.
- The compressor should be positioned in a closed room, where ambient air is cool and clean. Never block air flow to and from the room. Ensure sufficient inflow of cooling air and discharge of hot air outside the room. Temperature in a room with the compressor should be within the range of + 5°C to + 40°C.
- The air sucked in should contain no vapours or flammable gases, e.g. paint thinners, that might cause internal fire.
- There can be no objects close to the air inlet that could be sucked in with a jet of air.
- The pressure conduit connecting the compressor with the compressed air line should allow free expansion due to generated heat. It must not touch hot objects or flammable materials.

The detailed requirements concerning the machine positioning in the compressor room are described in section 4.1.

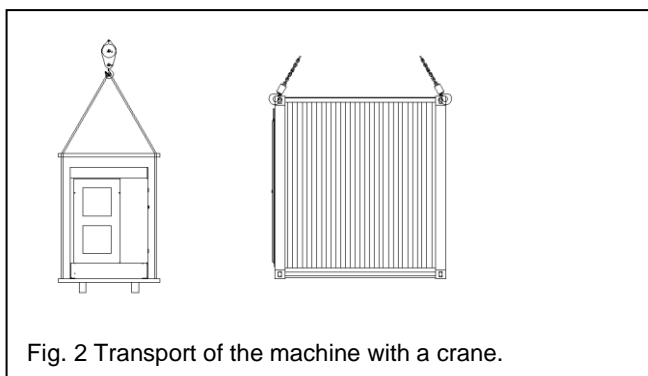
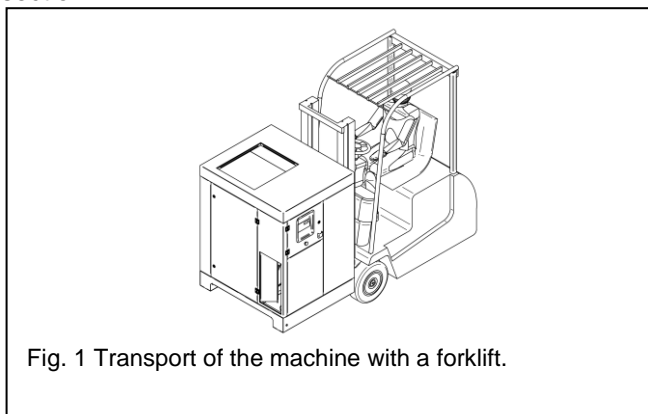

2.2. Operating safety requirements

In addition to the requirements contained in the sections: Screw compressor operation description; Start up; Maintenance; the following rules should be observed.

- The compressor is only designed to compress air.
- All safety equipment must be in place while operating the machine.
- The factory-mounted safety equipment must not be removed. Please, remember to remove any transport brackets (if applicable) before first start-up of the compressor. The transport brackets are only used to protect the machine during transport.
- There are hot parts in the compressor e.g. conduits, air and oil coolers, screw block. They will scald when touched.
- No unauthorized modifications in the control system are allowed. After power failure, the compressor must be restarted when the power supply is recovered.
- It is prohibited to remove the green and yellow protective conductors that prevent electric shock.
- No additional equipment can be mounted on the air receiver (except for the equipment allowed for use by the manufacturer).
- No welding operations or any other repairs can be performed on the air receiver.
- The plugs and other air receiver accessories can only be removed after the air receiver depressurisation to the ambient pressure.
- General safety rules should be observed while depressurising the air receiver. Air must be vented slowly. Keep the air stream away from people.
- Do not allow oil spill around the compressor.
- It is strictly prohibited to service the safety valves or to change their settings.
- Do not change settings of the pressure switches above the value given in the identification plate or in the Operating and Maintenance Manual.
- Fulfil the obligation to register the compressor air receiver in the Office of Technical Inspection (UDT). Two sets of the required documents of the air tank (if provided) and safety valve are included with the compressor documentation. The compressor documentation is accompanied by the set of the required documentation of the air receiver (if applicable) and safety valve.
- Do not remove the temperature sensor (transmitter) or pressure transmitter.



2.3. Other hazards

The compressor installation, switching on/off and maintenance must be carried out by the qualified personnel who strictly follows the data included in the product technical documentation and safety rules to avoid any hazards. The risks that could not have been eliminated during the design stage are described in the table below.

Unit	Residual risk	Action	Precautions
Air cooler, guard, frame	Minor cuts	Touching	Avoid touching, wear protective gloves.
Fan guard and fan	Injuries	Inserting sharp objects through the protection mesh when the fan is running.	Do not insert any objects through the protection mesh and do not put any objects on it.
Screw block, oil tank, end cooler, pressure conduits	Danger of scalds	Touching	Avoid touching, wear protective gloves.
Metal parts and electric cables	Electric shock	Damage of electric cable insulation upstream the motor breaker, live metal parts	Suitable guard for the power supply cable; check the cable insulation for damage.



2.4. Meaning of pictograms

Pictograms (safety symbols) located on and inside the compressor are described below. Explanation is provided below any of them. For technical reasons, it is not always possible to attach the pictograms in the very vicinity of the points of risk.

		
AUTOMATIC MACHINERY MAY START	RISK OF SCALDING	RISK OF ELECTRIC SHOCK

3. Identification plate

The identification plate as shown below is attached to the compressor housing or frame. When contacting us regarding your compressor, please provide the data given on the identification plate: compressor type, year of manufacture and factory number.

	BERG Kompressoren GmbH 40221 Düsseldorf Germany www.berg-kompressoren.de	LUFTKOMPRESSOR AIR COMPRESSOR
Durchflusskapazität Flow capacity (m ³ /min)	<input type="text"/>	Typ / Type <input type="text"/>
Max. Betriebsdruck (bar) Max. working pressure	<input type="text"/>	Herstellungsjahr Production year <input type="text"/>
Min./Max Arbeitstemperatur Min./Max working temp. (°C)	<input type="text"/>	Serienr. / S/Nr. <input type="text"/>
Motorleistung Motor Power (kw)	<input type="text"/>	

4. Setting

4.1. Room requirements

- The compressor requires no foundations. It must be positioned on a hard and even surface. Take into consideration the floor load capacity, if the machine is installed in a building.
- Strictly observe the minimum distances from walls and other machines. When several compressors are installed, pay attention to the direction of cooling air flow; no compressor should suck air which is heated by other machine. Minimum distances from the room walls and other objects are given in the drawings below.
- Protect the room in which the compressor is installed from negative temperatures. The inlets and outlets to and from the room should be located in such a manner to protect the interior from weather conditions.
- Heat generated during compression should be extracted outside (or to other rooms), and fresh air should be supplied from the outside.

- If the gravity ventilation is insufficient (windows, openings in a wall etc.) in the compressor room, air exchange should be provided by fans. To ensure correct heat extraction, the fans should have total capacity about 15 to 20% higher than the total cooling air requirement for all compressors installed in the room. The required cooling air volume is specified in the Technical Data section.
- Ambient temperature in the room should be from + 5°C to +40°C.
- Provide sufficient room for maintenance operations.
- It is necessary to consult our specialists when you want to install a duct supplying air from the outside or use air for heating the rooms.
- The compressor room should be well lighted to ensure trouble-free and safe service of the equipment.
- To improve ventilation in the compressor room, the machine can be connected to the discharge air duct; in such case, please contact BERG.

The suitable ventilation in a room will prevent the possibility of negative pressure generation or undesired temperature increase.

When there are any problems in ensuring the suitable ventilation in a room, please contact BERG.

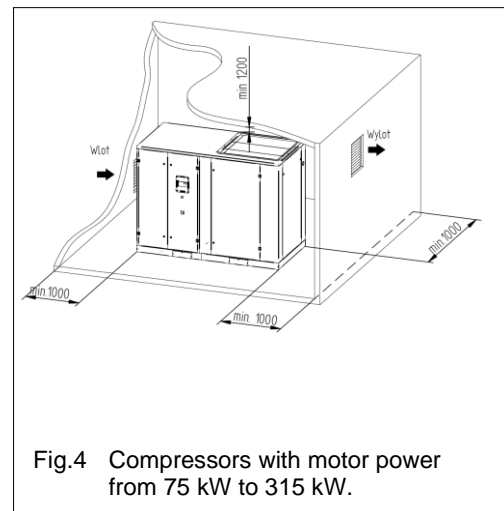
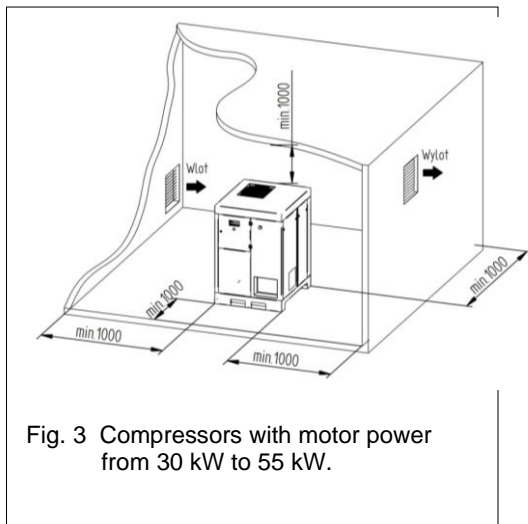

4.2. Requirements concerning electrical system

- Compressors are designed to be powered from a four-wire AC network with parameters given in the technical data (part II of the manual),
- Compressors with a built-in compressed air treatment system, are designed to be powered from a five-wire alternating current network with the parameters given in the technical data (part II of the operating manual),
- The compressors are equipped with PE terminal.
- The power cable cross sectional area should be matched to the current drawn by the compressor, (recommended cable size is given in the technical data - Part II of the operating manual).
- The compressors can only be operated on three-phase earthed system (TN).
- The compressor must be supplied from the distribution board equipped with a slow blow fuse and circuit-breaker that enables the compressor power supply to be completely disconnected.
- If a residual current circuit breaker is used for the circuits supplying the compressor with frequency converter, a type B RCD in accordance with IEC/EN 60755 must be used.
- Electrical connection of the compressor should be performed in accordance with the attached electrical diagram.
- Only authorised personnel or qualified electrician is allowed to perform electrical connections.
- Use the required safety measures in accordance with the suitable regulations.

- Calculate the power cable cross sectional area and fuse sizes according to the local regulations and operating conditions.
- Below there are presented the recommended power cable cross sectional areas and fuse sizes for standard compressors.
- A user takes a full responsibility for selection of an electrical system and power supply connection for the compressor.

Recommended power cable cross sectional area and fuse size.

Item	Compressor type	Recommended power cable cross sectional area mm ²	Fuse size	
			NH gL/gG, 500V, 100kA	D gL/gG, 500V, 50kA
1	KOMPBERG BSDL 22	3x16+PE		60
2	KOMPBERG BSDL 30	3x25+PE		80
3	KOMPBERG BSDL 37	3x35+PE		100
4	KOMPBERG BSDL 45	3x50+PE		125
5	KOMPBERG BSDL 55	3x50+PE		125
6	KOMPBERG BSDL 75	3x70+PE		160
7	KOMPBERG BSDL 90	3x95+PE		200
8	KOMPBERG BSDL 110	3x120+PE		250
9	KOMPBERG BSDL 132	3x150+PE		315
10	KOMPBERG BSDL 160	3x240+PE		400
11	KOMPBERG BSDL 200	3x300+PE		500
12	KOMPBERG BSDL 250	2x(3x185)+PE		630

4.3. Compressed air connection



It is recommended to use galvanized steel or plastic tubes for the compressed air system.

When the compressed air treatment equipment (filters, dryer) is installed, the existing compressed air piping should be replaced with a new one, unless air supplied previously was treated by similar equipment.

Each BERG compressor should be connected to the compressed air network by using a flexible conduit or flexible connector (axial expansion joint) and shut-off valve.

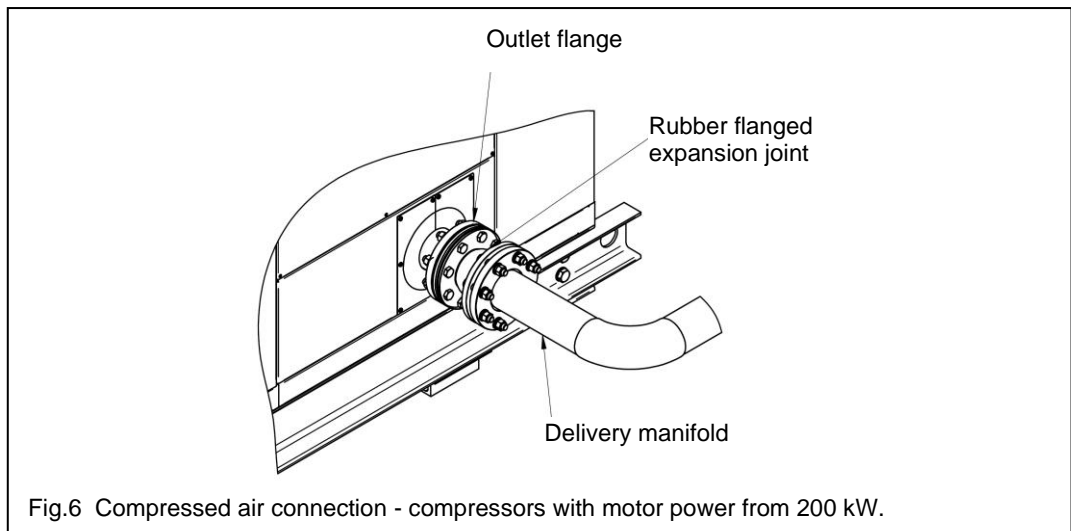
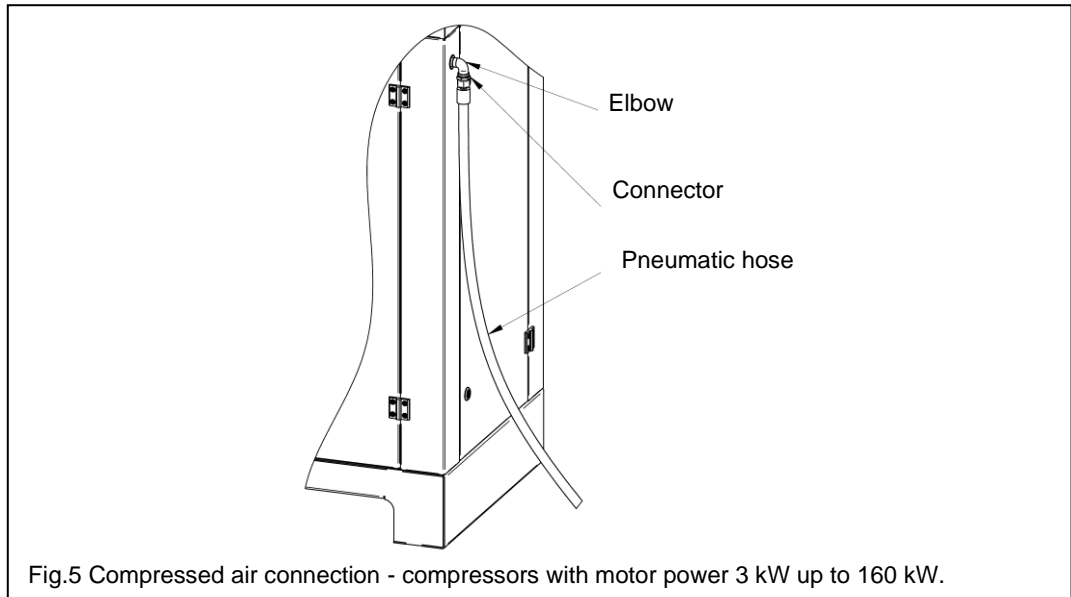

4.4. Compressed air treatment

Depending on the required quality of compressed air, some compressed air treatment equipment such as water separators, filters or dryer should be additionally installed downstream the compressor.

Our specialists will select the appropriate equipment free of charge.

5. Operation description

5.1. Screw compressors operation description

The compressor is started by pressing the START button on the controller. When the button is pressed, the compressor drive is started (the start can be delayed). During the initial start-up phase, the motor operates in the star configuration (for compressors with motor power up to 4 kW inclusive, the start-up is direct). When it is switched to the delta configuration, the solenoid valve which controls the suction regulator operation is energised, and compressed air is supplied to the actuator of the suction regulator. After a few seconds, needed for overpressure to be generated (approx. 0.2 MPa), the suction regulator opens in the suction regulator actuator. The ambient air, sucked through the air filter, flows into the screw block in which it is compressed. All the time the compressor is running, oil is injected into the screw block to provide lubrication, cooling and sealing. When the appropriate pressure (approx. 0.5 MPa) is reached in the pre-separator or the oil tank, the minimum pressure valve is opened and compressed air is delivered to the compressed air system. The minimum pressure valve functions also as the check valve. When compressed air is being delivered, this valve maintains the minimum overpressure (approx. 0.5 MPa) in the oil system, that is necessary to ensure correct lubrication and cooling.

The oil contained in the air being delivered is separated:

- initially in the pre-separator or inside the oil tank,
- precisely in the oil separator.

The oil flows from the screw block via the thermostat to the oil cooler, and then returns via the oil filter to the screw block.

The treated compressed air flows through the minimum pressure valve to the end cooler, and then to the compressed air receiver.

The compressor is adapted to intermittent operation. The intermittent operation involves delivery of compressed air until the maximum overpressure set in the controller is reached.

On reaching that pressure, the solenoid valve which controls the suction regulator operation is de-energised, or power supply is switched on and, consequently, the suction regulator is closed. The compressor switches to the so-called idle run, the overpressure in the screw block drops down to the value of approx. 0.2 MPa which ensures sufficient injection of oil into the screw block. When the idle run time (3 - 5 minutes) set in the controller elapses, the motor power supply is turned off and the compressor switches to the stand-by mode.

The compressor is restarted when the overpressure in the system drops to the minimum value set in the controller.

The compressor operation can be stopped at any time by pressing the STOP button on the control panel.

The operation is resumed by pressing the START button.

When the overpressure in the system exceeds the start value set in the controller on the compressor start, the compressor will start only after the overpressure drops to the set minimum value.

When the compressor is stopped by pressing the EMERGENCY STOP (STOP AWARYJNY) button and when the power returns after a power supply failure, the compressor can be started by resetting the EMERGENCY STOP button and pressing the OPERATION button.

The microprocessor controller has an additional function, preventing the compressor from starting under pressure, by measuring the time necessary to unload pressure from the screw block.

5.2. Screw compressors with inverter operation description

The compressor is started by pressing the START button on the controller - it is not necessary to start the inverter separately. When the button is pressed, the compressor drive is started. After a few seconds delay, the solenoid valve which controls the suction regulator is energized, and compressed air is supplied to the suction regulator actuator. After a few seconds, needed for overpressure to be generated (approx. 0.2 MPa), the suction regulator opens in the suction regulator actuator. The ambient air, sucked through the air filter, flows into the screw block in which it is compressed. All the time the compressor is running, oil is injected into the screw block to provide lubrication, cooling and sealing. When the appropriate pressure (approx. 0.5 MPa) is reached in the pre-separator or the oil tank, the minimum pressure valve is opened and compressed air is delivered to the compressed air system. The minimum pressure valve functions also as the check valve. When compressed air is being delivered, this valve maintains the minimum overpressure (approx. 0.5 MPa) in the screw block, pre-separator or oil tank, that is necessary to ensure correct lubrication and cooling.

The oil contained in the air being delivered is separated:

- initially in the pre-separator or inside the oil tank,
- precisely in the oil separator.

The oil flows from the screw block via the thermostat to the oil cooler, and then returns via the oil filter to the screw block.

The treated compressed air flows through the minimum pressure valve to the end cooler, and then to the compressed air receiver.

The compressor responds to the compressed air requirement by increasing/decreasing the motor speed when the pressure decreases/increases. When the maximum operating pressure is reached, the motor speed decreases to the minimum one (as set in the inverter controller). If no compressed air is drawn, the suction regulator closes and the compressor operates in idle run. If no compressed air is drawn, the drive will switch off after approx. 3 to 5 minutes. The compressor switches to the stand-by mode. During the idle run, the overpressure inside the screw block or oil tank drops down to the value of approx. 0.2 MPa which ensures sufficient injection of oil into the screw block. The compressor is restarted when the overpressure in the system drops to the minimum value set in the controller.

The compressor operation can be stopped at any time by pressing the STOP button on the control panel.

The operation is resumed by pressing the START button.

When the overpressure in the system exceeds the start value set in the controller on the compressor start, the compressor will start only after the overpressure drops to the set minimum value.

When the compressor is stopped by pressing the EMERGENCY STOP (STOP AWARYJNY) button and when the power returns after a power supply failure, the compressor can be started by resetting the EMERGENCY STOP button and pressing the OPERATION button.

The microprocessor controller has an additional function, preventing the compressor from starting under pressure, by measuring the time necessary to unload pressure from the screw block.



Refer to the microprocessor controller manual delivered with each compressor for detailed operation and setup procedures.

Refer to the inverter manual delivered with each compressor for detailed operation and setup procedures.

5.3. ULTRA SPEED function – in screw compressors with motor power of 5.5 kW - 90 kW and frequency converter

This function regulate the speed so that the power currently consumed is close to the nominal power of the engine. This results in rotation speed increase and thus capacity increase at operating pressure lower then nominal pressure.

This function is implemented by a second PID regulator located in the inverter and controlled by the DWEZ functionality.

The ultraspeed function enables higher compressor performance by setting a lower operating pressure. It provides the maximum possible compressor capacity for a given operating pressure while maintaining the nominal power of the device. The ultraspeed function is especially useful at times of excessive demand for compressed air. In the ultraspeed function, the main parameter managed by the controller is the main engine power. Lowering the operating pressure below the nominal pressure, it is possible to achieve higher capacity by increasing the speed of the main engine while maintaining the nominal power. The scope of performance is presented in the *Technical data* table contained in part II of the OMM.

6. Start-up

6.1. Start-up preparation

Each compressor unit is tested in the factory and carefully inspected to ensure proper machine performance and meeting the specifications declared.

Strictly obey the following rules before starting the machine for the first time:

- Get thoroughly familiar with the compressor Operating and Maintenance Manual and the Warranty Book.
- Check the power cables for possible damage, short-circuits and electrical breakdowns. Only authorised / qualified electrician can perform work on electrical equipment and components.
- Make sure the power supply voltage is correct and the required protections are in place; do not connect the compressor to a power source of different voltage than that specified in the Operating and Maintenance Manual (II part of OMM).
- Connect the phase conductors correctly.
Control - in the electrical box on the K1 relay the diodes should be lit continuously, which confirms correct phase connections, in accordance to the correct rotation direction of the rotors. The speed is marked on the screw stage, belt gear cover or clutch cover.
- The correct rotation direction is as indicated on the screw block, motor, belt transmission guard or coupling guard.
Correct rotation direction of screw airend rotors should be checked during the first start-up.



Incorrect rotation direction of the screw block rotors for more than 5 seconds will damage the screw compressor.

- Check the oil level in the screw block or in the oil tank and top it up, if necessary.
- Check the tension of V-belts or inspect the elastic coupling condition.
- Connect the compressor to the compressed air system with a flexible conduit.
- A compressed air receiver tank is necessary for proper compressor operation.
- When the compressed air receiver tank is located outside the compressor room, install the pressure gauge, connected to the tank or pressure conduit supplying the tank, in a visible location.
- Do not operate the compressor above the maximum operating pressure that is given on the identification plate. It is not recommended to operate the compressor at the delivery pressure below 0.5 MPa. Please contact our technicians when it is necessary to set that overpressure.
- Check if all doors/covers are closed.
- Open the valve that shuts off the compressor from compressed air system.
- Check the "EMERGENCY STOP" button position.
- Switch on the compressor power supply.

When the compressor and compressed air system condition is checked, you can proceed with starting the compressor.

To start the compressor, press the "START" button on the control panel. The compressor motor starts working and depending on the overpressure in the compressed air system, the machine switches to the loaded operation mode or, if the overpressure in the compressed air system is higher than the minimum start pressure, it switches to the stand-by mode and starts again after its drop.

6.2. Restart (after longer downtime)

Follow the procedure described below to start the compressor which has been out of use or stored for over 3 months:

- Check if there is no water in the oil tank. If necessary, remove water from the tank.
- Turn the compressor shaft several times by hand in the rotating direction.
- Lubricate the rotors in the screw block. To do this, remove the air filter and its housing from the suction regulator or disconnect the hose supplying air from the filter to the suction regulator. Pour oil into the suction regulator. The necessary oil volume depends on the compressor power. In the case of power up to 22 kW inclusive, pour 0.25 l of oil, and for power above 22 kW, pour 0.5 l of oil.
- After pouring the oil, wait one minute and check its level once again.
- Turn the compressor shaft several times by hand in the rotating direction.
- Check the oil level in the tank.
- Check the tension of the V-belts or the condition of the flexible coupling.
- Check that all doors / covers are closed.
- Open the valve shutting off the compressor from the compressed air network.
- Turn on the machine power.
- Check the position of the "EMERGENCY STOP" button.

After checking of the compressor and compressed air system condition, you can start the compressor.

Press the "START" button on the control panel. The compressor motor starts running and, depending on the overpressure in the compressed air system, the machine switches to load mode or, if the overpressure in the network is higher than the minimum switch-on pressure, it switches to standby mode and starts again when the pressure drops.

Perform the trial run of the compressor screw block lasting for at least a few minutes.

During the trial run, check the machine for correct operation, noise, vibration, oil leaks and tightness of connections in the compressed air system.

- Do not operate the compressor above the maximum pressure stated on the compressor identification plate. Compressor operation at a discharge pressure below 0.5 MPa is not recommended. If you need to set this overpressure, please contact our specialists.

7. Procedure in case of compressor self-deactivation or shutdown by using the emergency stop.

7.1. Self-deactivation

Read the information displayed on the controller and then follow the instructions in the user's manual. If the compressor has turned itself off and there are no messages on the controller:

1. Disconnect the power supply by the main switch.
2. Close the shut-off valve in the compressed air network (mounted behind the compressor).
3. Wait 5 minutes till the internal compressor systems have been emptied from pressure.
4. Check that the system has been emptied by slowly unscrewing the oil filler cap (use protective clothing). The compressed air may be hot.
5. Take the device out of operation, protecting it against inadvertent starting.
6. Call for service.

7.2. Shutdown by using the emergency stop.

1. Disconnect the power supply by the main switch.

2. Close the shut-off valve in the compressed air network (mounted behind the compressor).
3. Wait 5 minutes till the internal compressor systems have been emptied from pressure.
4. Check that the system has been emptied by slowly unscrewing the oil filler cap (use protective clothing). The compressed air may be hot.
5. Take the device out of operation, protecting it against inadvertent starting.
6. Call for service.

8. Maintenance

8.1 General requirements

To ensure proper functioning, the compressor must undergo maintenance procedures. The following general requirements must be met while performing the maintenance:

- Place the warning sign as shown below in a visible location, while the maintenance work is in progress:

WARNING
MACHINE UNDER REPAIR

- All maintenance work should be performed by authorised and trained personnel. Contact the factory service in case of technical problems.
- Before any maintenance work is started on the compressor, disconnect it from power supply and protect from unauthorized and accidental starting.
- Check if the supply voltage is lacking.
- Any maintenance and repair work can only be carried out when the compressed air system is completely unloaded i.e. air pressure in the system is reduced to ambient pressure.
- Before restarting the machine, make sure that there is nobody working on the compressor and there are no people in the vicinity.
- Use appropriate tools for maintenance and repair work.
- Use only original spare parts.
- For cleaning purposes never use flammable or corrosive solvents that could damage the machine components. Take appropriate safety measures against toxic vapours from cleaning agents. Biodegradable detergents should be used.
- The workplace must be kept absolutely clean when maintenance work is carried out. Do not allow any parts to get contaminated. Parts and exposed holes should be covered with a clean cloth, paper or adhesive tape.
- Upon finishing the maintenance work, make sure no tools or other objects are left on or inside the compressor.
- Before restarting the machine after maintenance, check operating pressures, temperatures, time settings, and test the switching and control equipment for proper functioning.
- Protect the motor, air filters, electric components, control equipment etc. from penetration of moisture.
- Do not perform any welding or any other works generating heat close to the oil system.
- Under no circumstances should the noise absorbing material be removed or relocated.

The manufacturer accepts no responsibility for any damage and personal injuries resulting from failure to observe the present safety rules or from carelessness during operation, work and maintenance, even in circumstances not expressly mentioned in this Operating and Maintenance Manual.

In order to ensure fault-free operation of the compressor, observe the following instructions relating to periodic inspections and maintenance operations.

8.2. Maintenance and inspections

8.2.1. Maintenance at the beginning of the compressor use and after oil and V-belts (where applicable) change

After 2 hours of operation	<ul style="list-style-type: none"> - Check the oil level in the oil tank and top it up, if necessary. - Check and, if necessary, tension the V-belts (where applicable).
After 2 days of operation	<ul style="list-style-type: none"> - Check the oil level in the oil tank and top it up, if necessary. - Check and, if necessary, tension the V-belts (where applicable).
After one week of operation	<ul style="list-style-type: none"> - Check and, if necessary, tension the V-belts (where applicable).

8.2.2 Daily maintenance

- Visually inspect the condition of the pneumatic and oil conduit connections.
- Check the air overpressure gauge and temperature indicator for correct readings.
- Check the compressor behaviour during operation for unusual symptoms such as excessive noise and vibration.
- Check the oil level.
- Check the condition and tension of the V-belts (where applicable).
- Check fastening of the covers and guards for loose screw joints.

8.2.3 Periodic maintenance

Every 100 hours of the compressor operation or after a longer downtime, you must:

- Check the oil level and top it up, if necessary.
- Check the tank for the presence of condensate and remove condensate, if necessary.

Every one week you should:

- Check the V-belts (if any) and tighten if necessary,
- Drain the condensate from the tank,
- Check service messages,
- Check the oil level,
- Clean the oil and air cooler fins.

Every 1000 hours, you must:

- Check the air filter for dirt and replace its cartridge, if necessary (in case of dusty environments it is recommended to clean and replace the filter cartridge more often).
- Check the condition and tension of the V-belts (tension them if necessary) or the condition of the elastic coupling.
- Clean the air and oil cooler fins if necessary.
- Check the safety valve for correct operation.

8.2.4 Warranty and post-warranty inspections

Screw compressors from 22- 55 kW

Required servicing	3000	6000	9000	12000	15000	18000	21000	24000	27000	30000	33000	36000	39000
Air filter element change	X	X	X	X	X	X	X	X	X	X	X	X	X
Oil filter change	X	X	X	X	X	X	X	X	X	X	X	X	X
Checking electrical connections and cables	X	X	X	X	X	X	X	X	X	X	X	X	X
Connectors and connections of controller check	X	X	X	X	X	X	X	X	X	X	X	X	X
Safety valve function check				X									X
Screw air end bearings check				X									X
Vibration dampers of motor and screw air end check				X				X					X
Motor bearings check		X				X				X			X
Control system check	X	X	X	X	X	X	X	X	X	X	X	X	X
Minimum pressure valve check	X	X	X	X	X	X	X	X	X	X	X	X	X
Separator oil drain system check	X	X	X	X	X	X	X	X	X	X	X	X	X
Thermistor settings and operation check	X	X	X	X	X	X	X	X	X	X	X	X	X
Monitor wear indications of the frequency check and replacement if necessary	X	X	X	X	X	X	X	X	X	X	X	X	X
Oil change	X	X	X	X	X	X	X	X	X	X	X	X	X
Separator change		X		X		X		X		X		X	
Contact control	X	X	X	X	X	X	X	X	X	X	X	X	X
Contact change								X					
Service inspection of the dryer (compressors with air dryer)	X	X	X	X	X	X	X	X	X	X	X	X	X
Service inspection of the dryer drain (compressors with air dryer)	X	X	X	X	X	X	X	X	X	X	X	X	X
Lubricate the motor bearings	X	X	X	X	X	X	X	X	X	X	X	X	X
Filter mat replacement	X	X	X	X	X	X	X	X	X	X	X	X	X
Compressed air pre-filter replacement (compressors with air dryer)	X	X	X	X	X	X	X	X	X	X	X	X	X
Compressed air fine-filter replacement (compressors with air dryer)	X	X	X	X	X	X	X	X	X	X	X	X	X
Thermostat cartridge replacement		X		X		X		X		X		X	
Minimum pressure valve repair kit replacement			X			X			X			X	
VMC suction valve repair kit replacement			X			X			X			X	
Solenoid valves replacement				X				X				X	
Pressure sensor replacement					X					X			
V-belts replacement*		X		X		X		X		X		X	
Coupling insert replacement*				X				X				X	
Hoses replacement								X					
Motor bearings (non-lubricated) replacement				X				X				X	
Motor bearings (lubricated) replacement								X					
Oil temperature sensor replacement					X					X			
Aie end shaft seal ring replacement			X			X					X		
Screw air end overhaul / replacement if necessary								X					

* if present

Required servicing	3000	6000	9000	12000	15000	18000	21000	24000	27000	30000	33000	36000	39000
Air filter element change	X	X	X	X	X	X	X	X	X	X	X	X	X
Oil filter change	X	X	X	X	X	X	X	X	X	X	X	X	X
Electrical connections and cables check	X	X	X	X	X	X	X	X	X	X	X	X	X
Connectors and connections of controller check	X	X	X	X	X	X	X	X	X	X	X	X	X
Safety valve function check				X									X
Screw air end bearings check				X									X
Vibration dampers of motor and screw air end check				X				X					X
Motor bearings check		X				X				X			X
Control system check	X	X	X	X	X	X	X	X	X	X	X	X	X
Unload system check	X	X	X	X	X	X	X	X	X	X	X	X	X
Minimum pressure valve check	X	X	X	X	X	X	X	X	X	X	X	X	X
Separator oil drain system check	X	X	X	X	X	X	X	X	X	X	X	X	X
Thermistor settings and operation check	X	X	X	X	X	X	X	X	X	X	X	X	X
Monitor wear indications of the frequency check and replacement if necessary	X	X	X	X	X	X	X	X	X	X	X	X	X
Oil change	X	X	X	X	X	X	X	X	X	X	X	X	X
Separator change		X		X		X		X		X		X	
Contactors check	X	X	X	X	X	X	X	X	X	X	X	X	X
Contactors change								X					
Service inspection of the dryer (compressor with dryer)	X	X	X	X	X	X	X	X	X	X	X	X	X
Service inspection of the dryer drain (compressor with dryer)	X	X	X	X	X	X	X	X	X	X	X	X	X
Lubricate the motor bearings	X	X	X	X	X	X	X	X	X	X	X	X	X
Filter mat replacement	X	X	X	X	X	X	X	X	X	X	X	X	X
Compressed air pre-filter replacement	X	X	X	X	X	X	X	X	X	X	X	X	X
Compressed air fine-filter replacement	X	X	X	X	X	X	X	X	X	X	X	X	X
Thermostat cartridge replacement		X		X		X		X		X		X	
Minimum pressure valve repair kit replacement			X			X			X				X
Suction valve repair kit replacement				X				X					X
Unload valve service kit replacement		X		X		X		X		X		X	
Solenoid valves replacement				X				X					X
Pressure sensor replacement					X					X			
Coupling insert replacement				X				X					X
Hoses replacement								X					
Motor bearings (non-lubricated) replacement				X				X					X
Motor bearings (lubricated) replacement								X					
Oil temperature sensor replacement					X					X			
Aie end shaft seal ring replacement			X			X					X		
Screw air end overhaul / replacement if necessary								X					

* if present



During the warranty period, the inspections must only be performed by the manufacturer service or authorised service centre listed in the Warranty Book every 3000 wh or once a year (depending what is first)

If the machine is operated in severe conditions, the maintenance work must be carried out more often.

The severe conditions include:

- Too low / high temperature in a room,
- Dusty environment,
- Frequent switching of the machine between idle and loaded running.

8.2.5 General remarks

- In case of short compressing cycles and long intervals between switching (the compressor does not reach the operating temperature between 70°C and 90 °C), there is a risk of condensate (water) accumulation inside the screw block or oil tank. The condensate should be regularly drained, every 100 hours of operation or once a week.
- Failure to perform and document the inspections will void the warranty.

8.3 Basic components requiring maintenance and descriptions of maintenance operations.

8.3.1. Air filter cartridge

The cartridge is located in the complete air filter assembly mounted on the suction side of the screw block. Do not soak the filter cartridge in oil or other liquids.

Maintenance procedure:

- Stop the compressor and close the pressure conduit valve.
- Switch off the power supply and take measures to prevent it from being unintentionally switched on again by unauthorised persons.
- Verify that the machine has been de-energised (0 V).
- Wait minimum 5 minutes and then open the compressor guard.
- Check that the system has been emptied by slowly unscrewing the oil filler cap (use protective clothing) (Fig.13). The compressed air can be hot.
- Open the filter cover and carefully remove the dust.
- Take the cartridge out, clean it or replace with a new one, if necessary.
- Cleaning by rinsing: do not apply force; in case of the cartridge damage, replace it with a new one.
- Clean the contact surfaces of the seals.
- Cleaning by blowing: blow the cartridge surface with dry compressed air, at the pressure of up to 0.5 MPa, in askew direction starting from its inside and then outside.
- Mount the filter cover, paying attention to its correct position during installation.
- Start the compressor and check for correct operation.

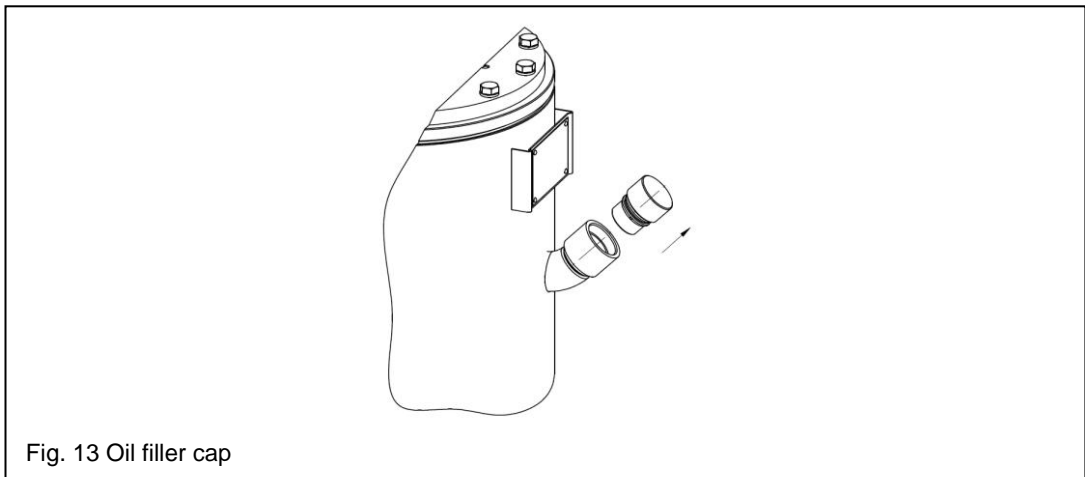
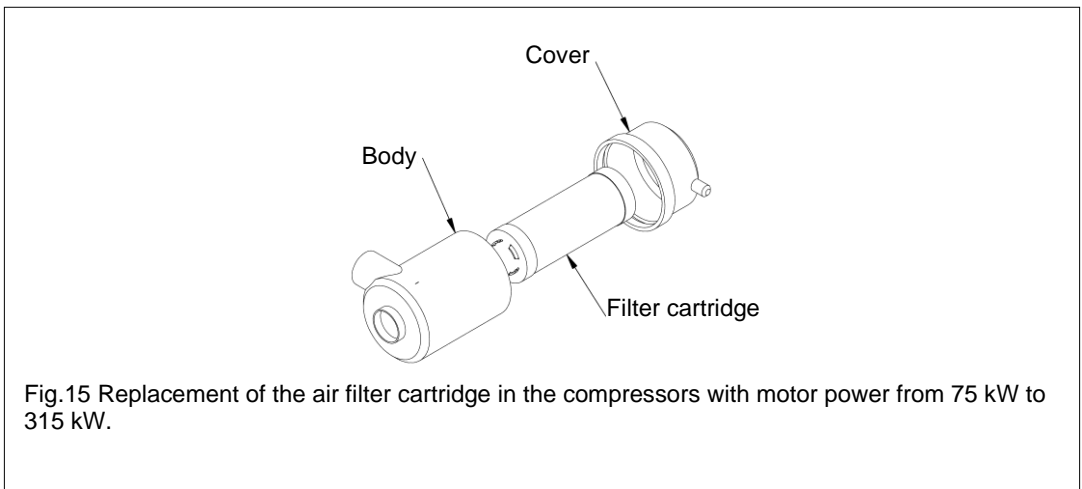
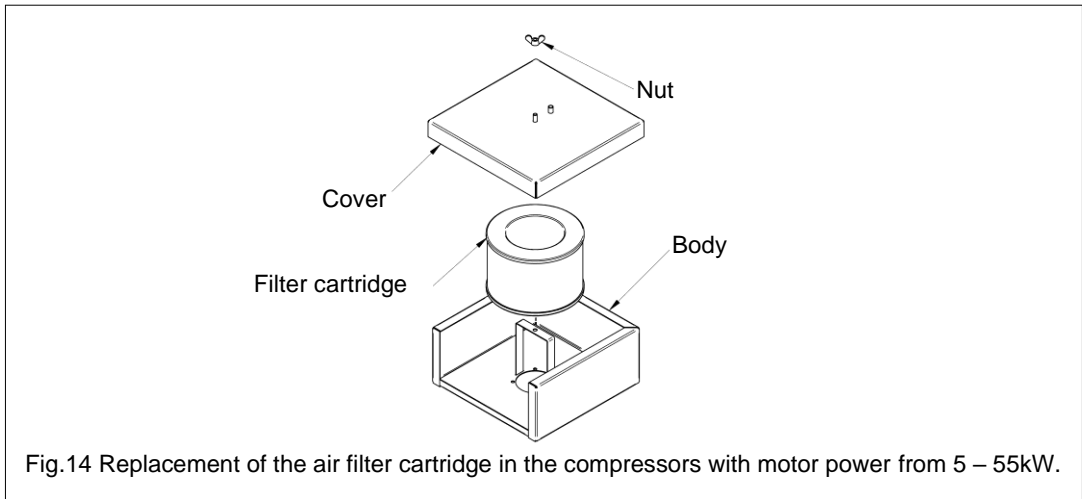

Fig. 13 Oil filler cap



8.3.2. Filter mat

The filter mat is installed at the air inlet(s) into the housing. If the filter mat gets dirty, cooling of the compressor may be insufficient.

Maintenance procedure:

1. When the compressor is switched off and has cooled down, carefully, without using any tools, remove the filter mat from the housing.
2. Clean the filter mat by tapping off the dust or using a vacuum cleaner. When the mat is heavily soiled, it can be washed in water and detergent.
3. When it is impossible to clean the mat or the mat is damaged, it should be replaced with a new one.
4. Carefully install the filter mat in the housing.

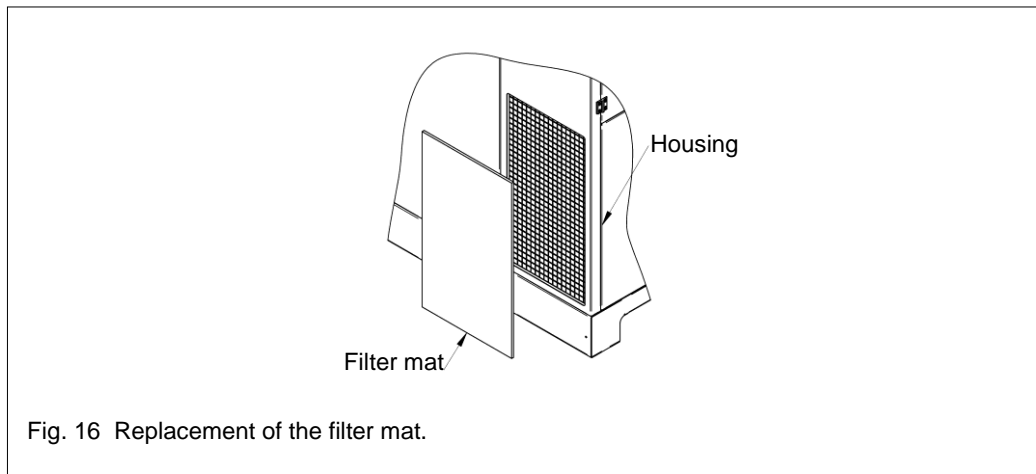

8.3.3. Oil filter

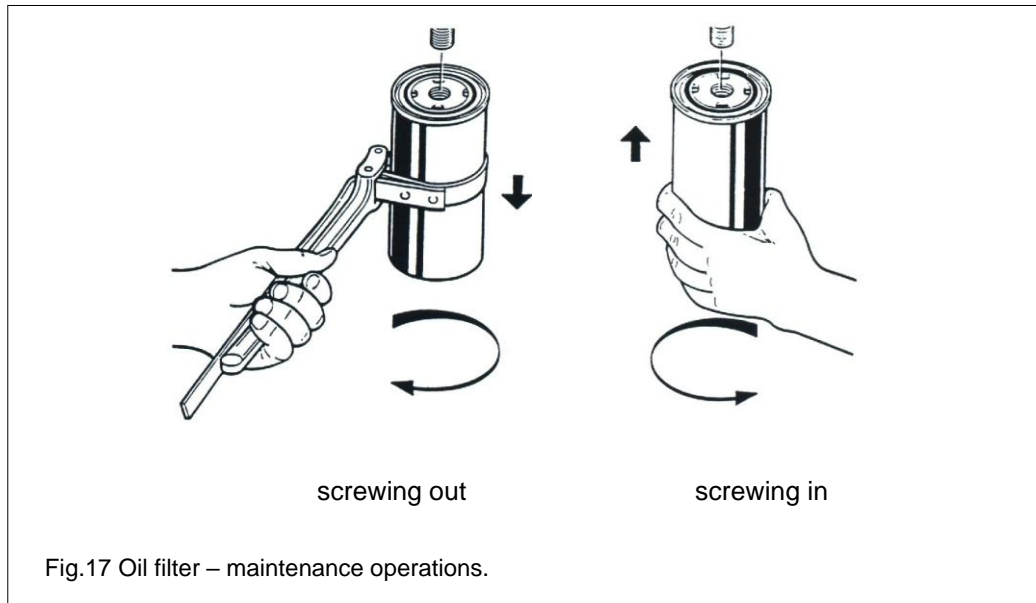

No dirt or dust particles should enter the screw block inside from the suction side.

Maintenance procedure:

- Stop the compressor and close the pressure conduit valve.
- Switch off the power supply and take measures to prevent it from being unintentionally switched on again by unauthorised persons.
- Wait minimum 5 minutes and then open the compressor housing.
- Check that the system has been emptied by slowly unscrewing the oil filler cap (use protective clothing) (Fig.13). The compressed air can be hot.
- It is advised to use the special spanner to replace the filter.
- Apply some oil onto the seal of the new oil filter before screwing it in. Then screw the filter in by hand, without using any tool.
- Start the compressor and check for leaks.



Caution: Hot oil.

8.3.4. Oil separator

When the air sucked in is highly contaminated or the operation takes place at elevated temperatures, the separator gets contaminated faster and the cartridge must be replaced more frequently. The need for an earlier replacement is indicated by the motor overload, too high oil temperature and, in extreme cases, activation of the safety valve. In the above cases, please consult the BERG service or authorised service centre listed in the Warranty Book.

The separator is designed to filter out the oil remains from the compressed air treated initially in the screw block body or oil tank.

After passing the effective separator, oil content in the compressed air is approx. 3mg/m^3 . The actual amount of oil consumed depends on many factors and may exceed the assumed amount of $<3\text{ mg/m}^3$. The amount of oil consumed depends on: operating temperature, frequency of pressure changes, pressure, number of compressor starts and stops, number of separator worked hours. Therefore, the average oil content in compressed air can be in the range of $5\text{-}8\text{ mg / m}^3$ and this is normal and for this value should be designed the treatment plant.



When the pressure difference between the compressed air and oil is above 0.1 MPa, change the separator, irrespective of the number of hours of operation.

In the BERG screw compressors there are used two types of oil separators: external (fig.18) or internal one (fig. 19).

External oil separator maintenance procedure:

- Stop the compressor and close the pressure conduit valve.
- Switch off the power supply and take measures to prevent it from being unintentionally switched on again by unauthorised persons.
- Verify that the machine has been de-energised (0 V).
- Wait minimum 5 minutes and then open the compressor cover.
- Check that the system has been emptied by slowly unscrewing the oil filler cap (use protective clothing) (Fig.13). The compressed air can be hot.
- Unscrew the oil separator using the same spanner as for oil filter; the separator is unscrewed counter clockwise.
- Before screwing the new separator in, apply a little oil onto the separator seal. Then screw it by hand into the coupling without using any tool.
- Start the compressor and check for leaks.



Caution: Hot oil.

Internal oil separator maintenance procedure:

- Stop the compressor and close the pressure conduit valve.
- Switch off the power supply and take measures to prevent it from being unintentionally switched on again by unauthorised persons.
- Verify that the machine has been de-energised (0 V).
- Wait minimum 5 minutes and then open the compressor cover.
- Check that the system has been emptied by slowly unscrewing the oil filler cap (use protective clothing) (Fig.13). The compressed air can be hot.
- Disconnect the pressure conduit from the minimum pressure valve, unscrew the oil tank cover and remove the separator cartridge. Caution: Hot oil.
- Install the new separator cartridge with the seal, screw the oil tank cover and reconnect the pressure conduit.
- Fasten the earth bolt securely to the tank cover.
- Start the compressor and check for leaks.



Caution: Hot oil.

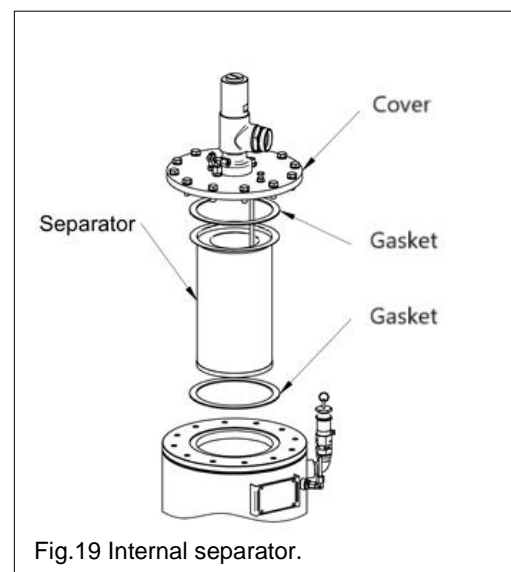
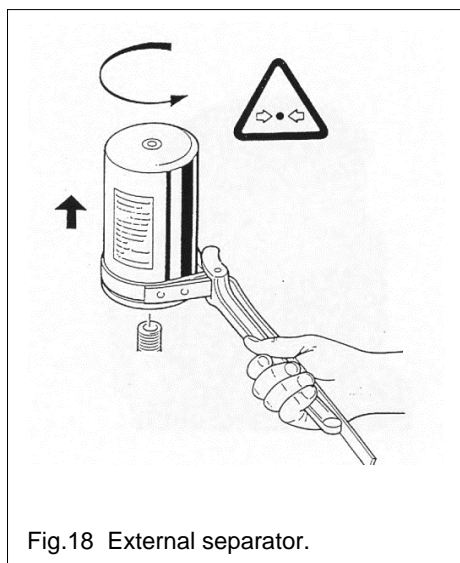

8.3.5. Oil level

The proper oil level in the oil tank or screw block is of critical importance for reliable and correct operation of the compressor.

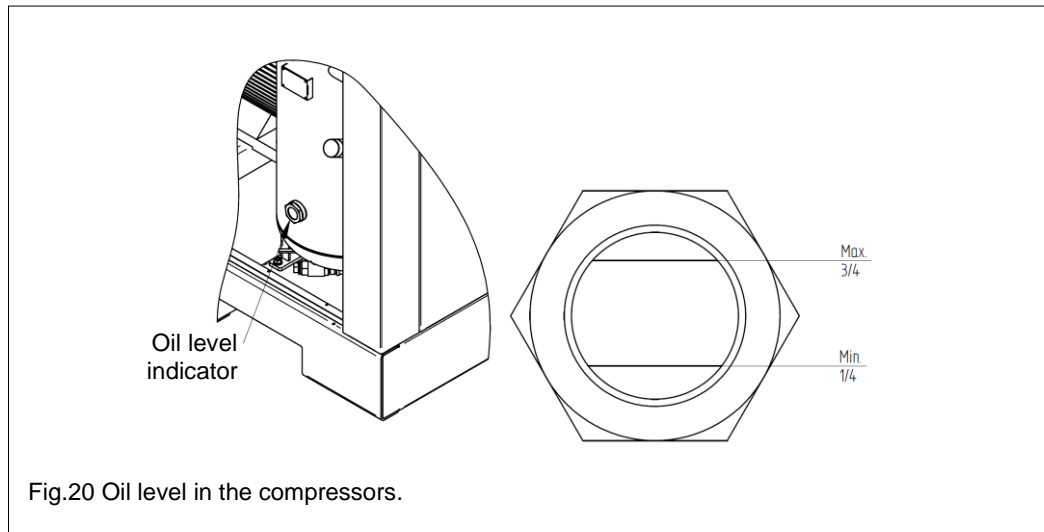

Maintenance procedure:

- Stop the compressor and close the pressure conduit valve.
- Switch off the power supply and take measures to prevent it from being unintentionally switched on again by unauthorised persons.
- Verify that the machine has been de-energised (0 V).
- Wait minimum 5 minutes and then open the compressor cover.
- Check that the system has been emptied by slowly unscrewing the oil filler cap (use protective clothing)(Fig.13). The compressed air can be hot.
- Check the oil level.
- If necessary, fill the oil up to the level that corresponds to 3/4 of the oil level indicator field height, using the same type of oil.
- Screw the oil fill plug tightly by hand.
- Start the compressor.
- Check the oil fill plug for leaks, and if necessary replace the sealing ring.



The oil level should be checked when the compressor is switched off and pressure has dropped to ambient pressure.

8.3.6. Water condensate draining

The presence of water condensate in oil has a significantly unfavourable effect on the operating safety and life of the screw compressor.



Warranty claims shall be excluded if excessive wear or damage of the bearings caused by water contained in oil is found. The condensate is formed when the screw compressor is operated in short runs only, i.e. below the temperature at which the thermostat in the oil circuit is activated. The condensate comes from the humid atmospheric air sucked into the screw block. When the compressor is stopped and cooled down, the moisture contained in the air inside the compressor pneumatic system condenses. The condensate should be drained from the cold screw compressor e.g. before starting work. Proceed the same way as when draining oil.

Maintenance procedure:

- Stop the compressor and close the pressure conduit valve.
- Switch off the power supply and take measures to prevent it from being unintentionally switched on again by unauthorised persons.
- Verify that the machine has been de-energised (0 V).
- Wait minimum 5 minutes and then open the compressor housing.
- Check that the system has been emptied by slowly unscrewing the oil filler cap (use protective clothing) (Fig.13). The compressed air can be hot.
- Position an appropriate oil catch container under the oil drain plug and carefully unscrew the oil drain plug.
- Drain the condensate from the body (oil tank) as long as oil appears, and then replace the oil drain plug.
- Replenish the oil through the fill port in the compressor body (or oil tank) to the maximum level, and then tightly screw the oil fill plug by hand.
- Start the screw compressor and let it run for about 3 minutes.
- Check the oil level: replenish the missing oil quantity up to the maximum level.
- Dispose the condensate in accordance with the applicable regulations.

8.3.7. Oil change and recommendations concerning oil

Oil change can only be done when the screw compressor is stopped and completely unloaded. The machine should be heated up to the operating temperature (oil temperature should be approx. 60°C to 80°C).

Maintenance procedure:

- Stop the compressor and close the pressure conduit valve.
- Switch off the power supply and take measures to prevent it from being unintentionally switched on again by unauthorised persons.
- Verify that the machine has been de-energised (0 V).
- Wait minimum 5 minutes and then open the compressor cover.
- The waste oil must be changed after previous machine heating, which ensures its fast and accurate draining into the catch container.
- Check that the system has been emptied by slowly unscrewing the oil filler cap (use protective clothing) (Fig.13). The compressed air can be hot.
- Position an appropriate oil catch container under the oil drain plug and carefully unscrew the oil drain plug.
- Drain the oil completely and then replace the oil drain plug.
- Pour new oil through the fill port to the maximum level and then tightly screw the oil fill plug by hand.
- Start the screw compressor and let it run for about 3 minutes.
- Check the oil level: replenish the missing oil quantity up to the maximum level.
- Dispose the waste oil in accordance with the applicable regulations.

In the screw compressors there is used the PNEUMOIL ST68 synthetic air compressor oil.

The compressor oil used must meet the following basic specifications:

Kinematic viscosity at 40°C	68 cST (mm ² /s)
Flow temperature	< - 45 °C
Flash point	min. 250 °C

In addition, the oil must:

- be resistant to oxidation,
- have very low susceptibility to emulsification,
- have very low foamability,
- provide good corrosion protection,
- have improved lubricating properties.



When oil is changed, you must absolutely maintain the same parameters. Otherwise, the machine may get damaged.

Mixing of different oil types is not allowed.

Always use the same brand and type of oil for topping up.

8.3.8. Handling wastes produced while operating the compressors

The condensate from the compressor, tank or compressed air treatment equipment must not be drained directly to sewage system. It should be disposed in accordance with the applicable waste management regulations; waste code 13 05 07.

Waste oil should be disposed in accordance with the applicable waste management regulations; waste code 13 02 06.

Oil filters and oil filter cartridges should be disposed in accordance with the applicable waste management regulations; waste code 16 01 07.

8.3.9 Pressure switch

The pressure switch is connected with a conduit to the outlet connection (at the minimum pressure valve) of the compressor or to the air receiver

You are not allowed to change the maximum pressure setting above the value given on the identification plate of the compressor and to change the minimum pressure below 5 bar.

Pressure switch settings:

- Minimum pressure differential – 1.5 bar,
- Minimum cut-in pressure – 5.0 bar,
- Maximum cut-out pressure – according to the identification plate.

8.3.10 Oil temperature gauge (where applicable)

The oil temperature gauge is installed on the control panel. It monitors the permissible compressor oil operating temperature that is factory set to 110°C (red mark).

When that temperature is reached, the compressor power supply circuit is interrupted. The system switches off automatically. The compressor can be restarted when the cause of excessive temperature increase is removed and oil temperature is reduced.

8.3.11. Oil cooler / air cooler

The air/oil cooler must be regularly cleaned to ensure safe operation of the screw compressor. The cooling ribs of the cooler must be kept clean. This is the only way to ensure full cooling capacity. Sufficient cooling ensures lower oil temperature and thus longer life. It is therefore recommended to clean the cooler ribs with compressed air, jet of steam or detergent solution. If the aforementioned cleaning methods prove ineffective in reducing the operating temperature, the cooler components which the oil flows through must be cleaned internally to remove deposit using special deposit removal agents. To do this, remove the cooler.

In case of heavy contamination of the air being sucked (cooling air), it is necessary to clean the cooler more often, especially when the temperature of the compressed air at the compressor outlet is more than 15°C higher than the ambient temperature.

The cleaning frequency depends on the conditions existing in the room, where the compressor is located.

Maintenance procedure:

- Stop the compressor and close the pressure conduit valve.
- Switch off the power supply and take measures to prevent it from being unintentionally switched on again by unauthorised persons.
- Verify that the machine has been de-energised (0 V).
- Wait minimum 5 minutes and then open the compressor guard.
- Check that the system has been emptied by slowly unscrewing the oil filler cap (use protective clothing) (Fig.13). The compressed air can be hot.
- Remove the components that may hinder access to the cooler. If necessary, remove the cooler.
- Remove any dirt.
- Install all the removed components.
- Fill (replenish) the oil in the compressor (if necessary).
- Perform a trial run for about 3 to 5 minutes.
- Stop the compressor, check the oil level and top it up if necessary.



Do not use any sharp objects for cleaning, because they may damage the cooler.

8.3.12. Electric motor

When the compressor is running, check the motor operation by paying attention to the following:

- Operating noise,
- Excessive vibration,
- Excessive current consumption –protection activation in the electrical cabinet,
- The condition of the fixing screws,
- A degree of fouling.

The motor (compressor) should be stopped immediately in case of:

- Overheating,
- Smoke or burning smell,
- Excessive vibration,
- Bearing noise.



The machine can be restarted after removing the cause of any failures.

Periodic motor inspections:

The motor inspection should be performed at least once per 2 years.

The inspection should be performed by the in-house personnel or properly qualified personnel from specialized companies.

Any repairs or special inspections should be performed by the specialised workshop or the manufacturer service.

Replacement or lubrication of the motor bearings must be performed in accordance with the manufacturer's recommendations (motor nameplate). The permissible hours of the bearing operation to the replacement or lubrication are presented in the table below. When any symptoms indicating the bearing damage occur (unusual noise or increased temperatures), contact the service immediately.

Hours of operation until the performance of service operations			
Motor power	Bearing type	Hours of operation	Operations
3-22 kW	Maintenance-free	40000 h	Replacement
30-55 kW	Requiring maintenance	3000 h	Lubrication
75-90 kW	Requiring maintenance	2000 h	Lubrication
110-200 kW	Requiring maintenance	2000 h	Lubrication

8.3.14. Safety valve

The safety valves fulfil an important function in pressure equipment and systems. They require particularly careful and professional service. Any operational shortcomings may damage the valve mechanism, and consequently damage the entire pressure unit. Therefore, during the equipment operation particular attention should be paid to the following:

- Correct setting of the safety valve, appropriate to the operating parameters of the equipment being protected,
- Appropriate protection of the valve mechanism against unauthorized adjustment and a risk of damage. The valve seal must be intact,
- Periodic inspections of the valve for correct operation according to the requirements of the office of technical inspection regulations.

The safety valve operation inspection involves blowing the valve by pulling the handle (wheel) upwards. The pin, lifted by pulling the wheel up, releases the pressure of the

valve spring and moves the head a little up and allows the compressed air to flow through the valve.

The handle can be loosened at the pressure equal at least 50% of the operating pressure (fig.32 and fig. 33).

The valves delivered require no special maintenance. They should only be periodically (every 1000 hours) blown by pulling the handle of the push pin (fig. 21 and fig. 22). Special care must be taken while performing this operation. Keep away from the stream of air blown out (caution – the air may be hot!).

In case of the valve leaks, contact the manufacturer service to arrange its repair. The valve cannot be repaired by the user itself.

Blocking the pin, tightening the adjustment nut or covering the valve outlets is not allowed.

In addition to the guidelines and requirements listed in this paragraph, the user is obliged to observe the regulations being in force in the country in which the equipment is operated.

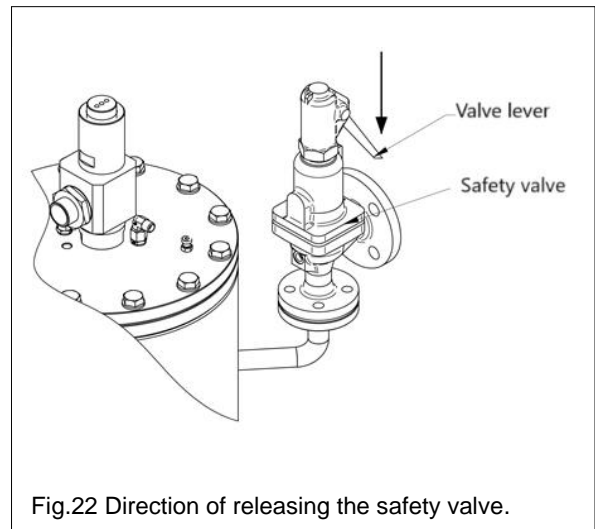
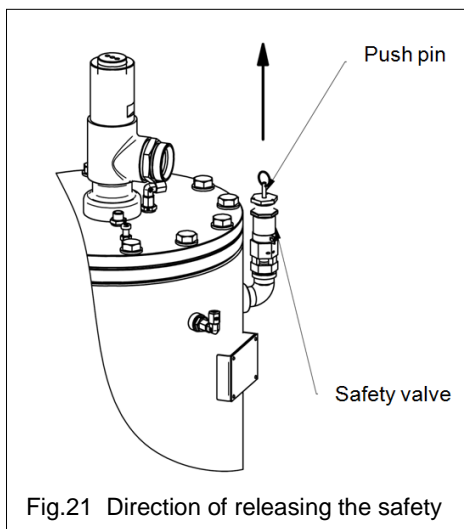

During the safety valve operation (when the compressed air is blown out through it) loud noise is generated. When any maintenance operations are carried out, you must wear hearing protection and safety clothes protecting against air stream.

You are not allowed to operate the machine in the system with the faulty safety valve. The faulty valve must be immediately replaced with a new one after the machine stopping and unloading.



The safety valves are only intended for protection of: pressure tanks, compressed air conduits or other neutral gases, sources of compressed air from an excessive increase in pressure (above the limit for that type of equipment).

The safety valves must not be used as relief devices for pressure adjustment.

8.3.15 Radial / axial fan

To ensure long and trouble-free operation of the radial or axial fan, the following rules and recommendations should be followed:

- Every 12 months check the valve for mechanical vibration. Max. permissible vibration force is 2.8 mm/s (measured on the bearing cover in the motor bearing at the rotor side). The periods between inspections may be shortened depending on a degree of fouling. It applies to the radial impellers.
- Keep the impeller clean. Dirt deposits on the impeller may result in imbalance and its failure (risk of fatigue cracks).
- Follow the motor manufacturer's information concerning its keeping in operative condition and maintenance.
- The fan air ducts must be free of foreign matters –hazards caused by the thrown out objects.
- Do not bend blades - imbalance.
- Pay attention to unusual operation sounds.
- Any repairs must only be performed by the specialised qualified personnel.

Maintenance procedure:

- Stop the compressor and close the pressure conduit valve.
- Switch off the power supply and take measures to prevent it from being unintentionally switched on again by unauthorised persons.
- Wait minimum 5 minutes and then open the compressor guard.
- Check that the system has been emptied by slowly unscrewing the oil filler cap (use protective clothing) (Fig.13). The compressed air can be hot.
- Open the cover that hinders access to the fan.
- Make sure that the fan impeller is not moving.
- Do not remove the impeller to clean it.
- Clean the impeller with the cloth soaked in mild detergent solution. Clean the flow area of the fan. Do not use any aggressive cleaning agents that may dissolve its paint. You are not allowed to use any pressure washers or strong water jet for cleaning.
- Check thoroughly the impeller, especially the welds (it applies to the radial impellers) for any cracks.
- Close the cover that hinders access to the fan.
- Start the compressor.
- Check the fan for correct operation.

When removal is necessary, the entire rotating unit needs to be balanced again according to DIN ISO 1940, part 1. (it applies to the radial impellers). The axial fans used because of light weight of their moving parts do not require to be balanced again.

Replacement or lubrication of the motor bearings must be performed in accordance with the manufacturer's recommendations. The permissible hours of the bearing operation to the replacement or lubrication are presented in the table below. When any symptoms indicating the bearing damage occur (unusual noise or increased temperatures), contact the service immediately.

Hours of operation until the performance of service operations			
Motor power	Bearing type	Hours of operation	Operations
0.75 kW	Maintenance-free	40000 h	Replacement
1.5 kW	Maintenance-free	40000 h	Replacement
4 kW	Maintenance-free	40000 h	Replacement
5.5 kW	Maintenance-free	40000 h	Replacement
7.5 kW	Maintenance-free	40000 h	Replacement
11 kW	Maintenance-free	40000 h	Replacement
15 kW	Maintenance-free	40000 h	Replacement

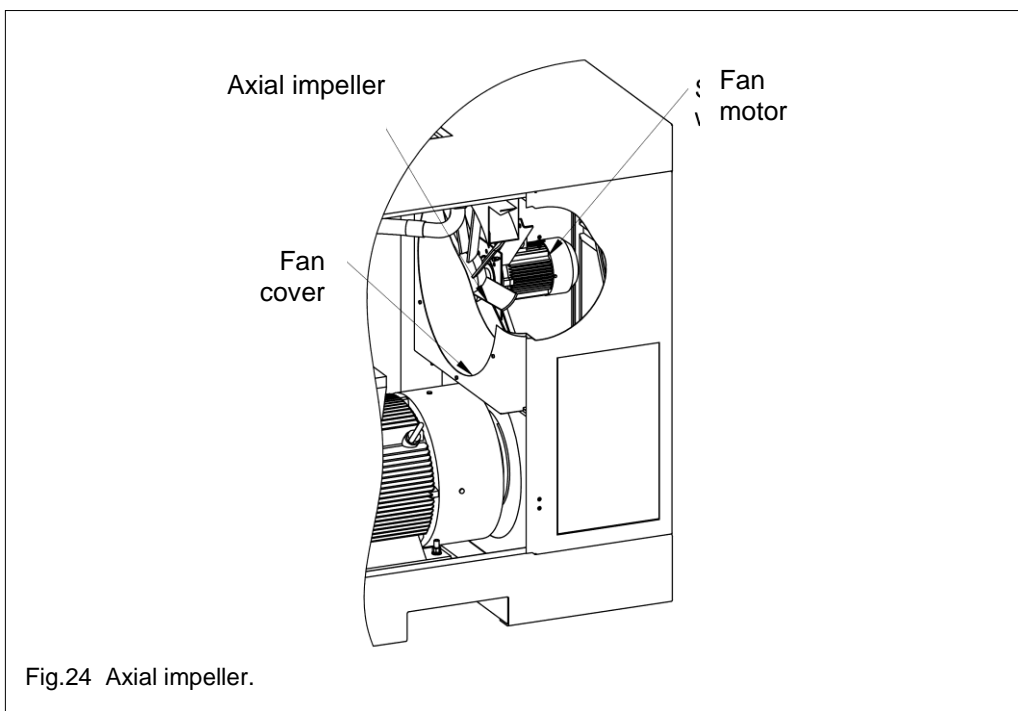
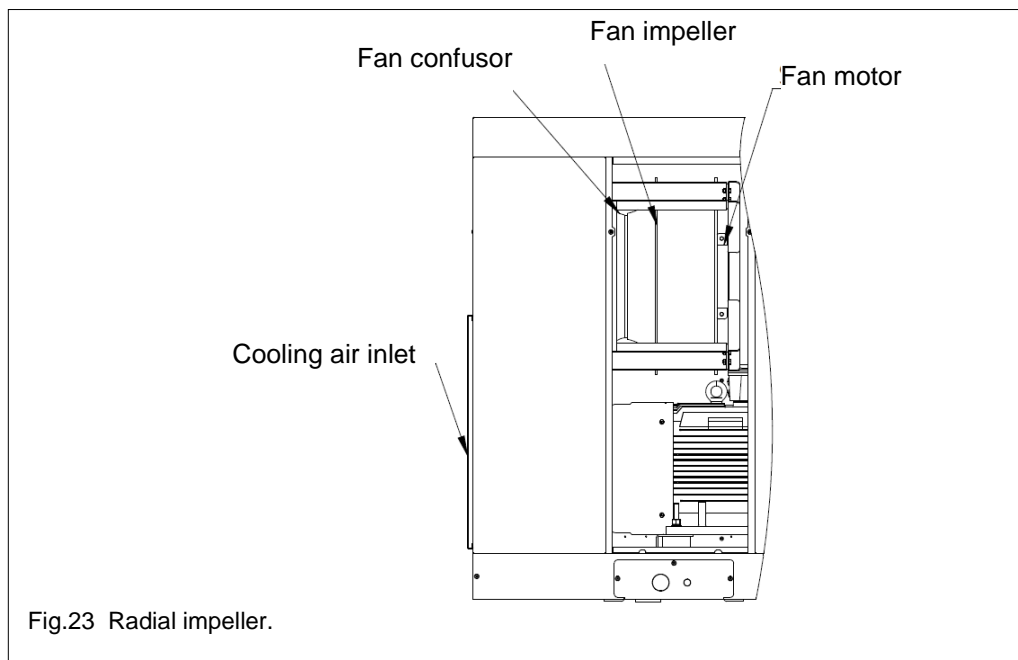

9. Troubleshooting

Symptom	Cause	Remedy
The compressor cannot start	Power supply failure	Check for the presence of voltage at the power cable terminals.
	Activation of the main protection	Check the protection, replace it with the new one when it is faulty. In other case, contact the BERG service or authorised service centre listed in the Warranty Book.
	Incorrect phase sequence (compressors with microprocessor control)	Change connection of two phase conductors on the compressor terminal block or in the distribution board.
	Faulty temperature sensor	In case of any malfunctions, contact the BERG service or authorised service centre listed in the Warranty Book.
	The temperature sensor (microprocessor controller) activated because of too high temperature	Check: <ul style="list-style-type: none"> - the oil level and top it up if necessary, - cooling: remove causes of insufficient cooling, - thermostat: contact the BERG service or authorised service centre listed in the Warranty Book.
The compressor is running, but it does not generate compressed air	The compressor is not connected to the compressed air system.	Connect the compressor to the compressed air system.
	The suction valve does not open or opens partially.	Check operation of the solenoid valve.
	Some leaks in the compressor pneumatic system or in the compressed air system.	Repair any leaks.
	Too high installation demand for compressed air.	Reduce the number of compressed air receivers, check the compressed air system for leaks and repair leaks if any.
Difficult start of the compressor	Too low supply voltage	Check the supply voltage and provide the correct, if necessary.
	Too low ambient temperature	Heat the room to temperature of at least +5°C.
	Oil is too thick	Oil is incorrect. Change the oil to the one recommended by the manufacturer.
Incorrect rotation direction	Incorrect phase sequence	Change connection of two phase conductors on the compressor terminal block or in the distribution board.
Too high oil temperature and the compressor is shut down	Ambient temperature >40°C	Provide sufficient ventilation of the room.
	Dirty cooler	Clean the cooler.
	Delivery pressure is higher than the set one.	Adjust the pressure switch or enter the correct settings into the controller.
	Too low oil level	Replenish the oil to the required level.

	Incorrect operation of the oil thermostat.	In case of any malfunctions, contact the BERG service or authorised service centre listed in the Warranty Book.
	Other causes	In case of any malfunctions, contact the BERG service or authorised service centre listed in the Warranty Book.
Too low delivery pressure	The pressure switch is set incorrectly or incorrect setting in the microprocessor controller.	Adjust the pressure switch or enter the correct settings into the controller.
	The compressor capacity is too low in relation to the compressed air demand.	Install an additional compressed air source or limit the number of compressed air receivers in the system.
	Leaky compressed air system.	Check the system for leaks and repair them.
	Dirty or faulty oil separator.	Replace with the new one (during the warranty period, any defects/ replacement needs must be reported to the BERG service or authorised service centre listed in the Warranty Book).
	Dirty air filter	Clean or replace the air filter cartridge, if necessary.
	Faulty suction regulator	In case of any malfunctions, contact the BERG service or authorised service centre listed in the Warranty Book.
Excessive oil quantity in the compressed air	Dirty or faulty oil separator.	Replace with the new one (during the warranty period, any defects/ replacement needs must be reported to the BERG service or authorised service centre listed in the Warranty Book).
	Incorrect oil	Change the oil to the one recommended by the manufacturer.
	The compressors starts too often	Install the additional compressed air receiver tank, increase the difference between cut-in and cut-out pressure of the compressor.
	Too short unloading time	Adjust the nozzles in the suction system. In case of any malfunctions, contact the BERG service or authorised service centre listed in the Warranty Book.
	No or insufficient suction of oil from the separator.	Dirty conduit or components in the suction system. In case of any malfunctions, contact the BERG service or authorised service centre listed in the Warranty Book.
	Too high oil level	Check and provide the correct oil level, if necessary.
Activation of the motor protection	Too high ambient temperature	Provide better ventilation of the room.
	Failure of one phase in the power supply of the motor.	Check the power cables, contactor and protection, check also the electrical system supplying the compressor.
	Too low supply voltage.	Provide correct supply voltage.

	Dirty separator	Replace with the new one (during the warranty period, any defects/ replacement needs must be reported to the BERG service or authorised service centre listed in the Warranty Book).
	Seized screw block.	Contact the BERG service or authorised service centre listed in the Warranty Book.
Activation of the safety valve	Faulty safety valve.	Replace with the new one (with appropriate settings) or contact the BERG service or authorised service centre listed in the Warranty Book.
	Dirty oil separator	Replace with the new one (in case of any malfunctions, contact the BERG service or authorised service centre listed in the Warranty Book).
	The pressure switch is set incorrectly or incorrect setting in the microprocessor controller.	Adjust the pressure switch or enter the correct settings into the controller.
	Faulty suction regulator.	In case of any malfunctions, contact the BERG service or authorised service centre listed in the Warranty Book.
Excessive wear or breaking of the V-belts	Too low tension of the V-belts	Tension the V-belts (item 7.3.10)
	Pulleys are not aligned.	Check and correctly adjust the pulleys.
	Blocked screw block.	In case of any malfunctions, contact the BERG service or authorised service centre listed in the Warranty Book.
	Too high vibration of the V-belt(s)	Check the tension of the belts. When there are high differences in tension of individual belts, replace the entire set of the belts with new one.
Excessive wear of the coupling insert	Misalignment of the motor shaft and the screw block	In case of any malfunctions, contact the BERG service or authorised service centre listed in the Warranty Book.
	Faulty screw block.	
Oil in the suction regulator when the compressor is stopped	Faulty suction regulator.	In case of any malfunctions, contact the BERG service or authorised service centre listed in the Warranty Book.
	Too high oil level	Check and provide the correct oil level, if necessary.
Malfunction of the inverter	Troubleshooting is included in the attached operating manual of the inverter. In case of any malfunctions, contact the BERG service or authorised service centre listed in the Warranty Book.	

PART II

Technical data
 Screw compressor drawings (compressor components layout, dimensions)
 Consumables
 Electric diagram
 Controller operating manual

SHOCK ABSORBERS MOUNTING

(performed by the user)

Screw compressor is equipped with shock absorbers which are delivered disassembled and must be mounted after unpacking the machine. To avoid the damage risk of oil-lubricated screw compressors during transport, their shock absorbers are attached separately, for self-assembly by the user.

During transport, shock absorbers are placed inside the compressor housing on specially prepared supports.

Before the first start-up, the customer is to install the shock absorbers in accordance with the attached instructions. Information how to mount the shock absorbers is contained in documentation of oil screw compressors.

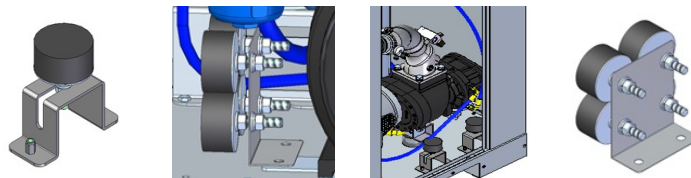

Follow the steps for mounting:

1. Read carefully the Compressor Operation Manual (in particular, Chapters 2 and 4 Part I, which deal with room requirements and minimum wall distance when positioning the compressor).
2. Dismantle the base cover plates (1) by unscrewing three fixing screws (2).
3. Lift the compressor off the pallet.
4. Attach the shock absorbers (3).
5. Place the compressor at its destination.
6. Level the compressor.
7. Install the base cover plates (1).

Attention!!! Take particular care when mounting the shock absorbers to the base.

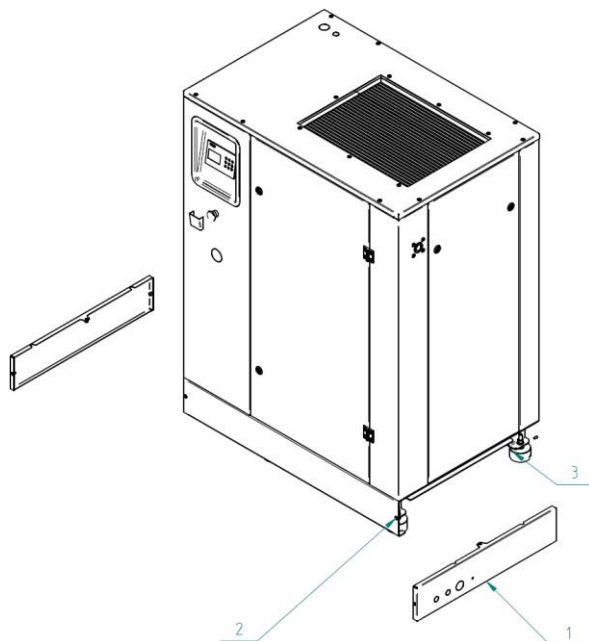

Screw compressors:

BSDF 22, BSDF 30, BSDF 37, BSDF 45, BSDF 55, BSDF 75, BSDF 90, BSDF 110, BSDF 132, BSDF 160, BSDF 200, BSDF 250,

Adjusting nut

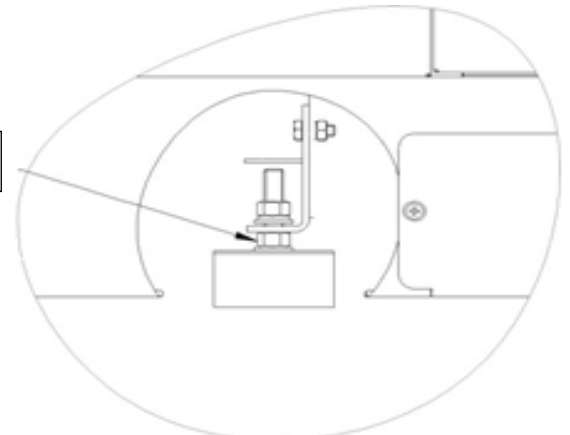

View of the shock absorber and the adjustment screw used to level the compressor.

LEVELING FEETS MOUNTING

(performed by the user)

Screw compressor is equipped with leveling feet which are delivered disassembled and must be mounted after unpacking the machine.

Follow the steps for mounting:

1. Read carefully the Compressor Operation Manual (in particular, Chapters 2 and 4 Part I, which deal with room requirements and minimum wall distance when positioning the compressor).
2. Dismantle the base cover plates (1) by unscrewing three fixing screws (2).
3. Lift the compressor off the pallet.
4. Attach the leveling feet (3).
5. Place the compressor at its destination.
6. Level the compressor.
7. Install the base cover plates (1).

Attention!!! Take particular care when mounting the leveling feet to the base.

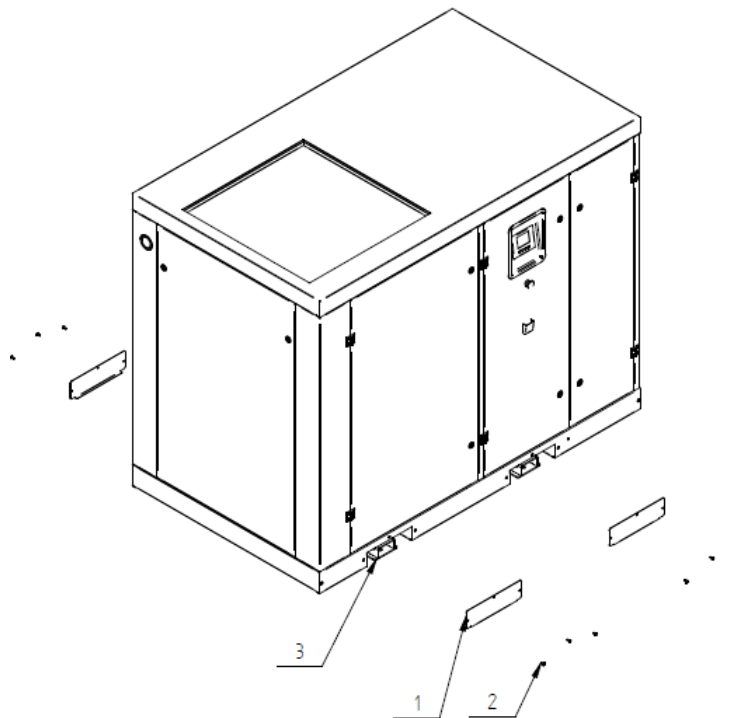

BSDF 75 screw compressors

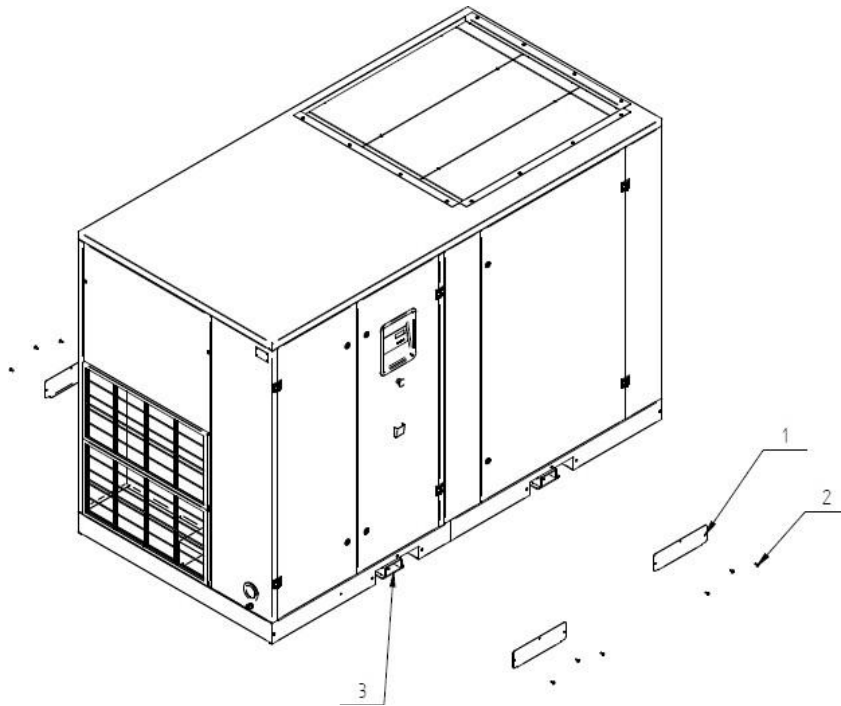

BSDF 90, BSDF 110 screw compressors

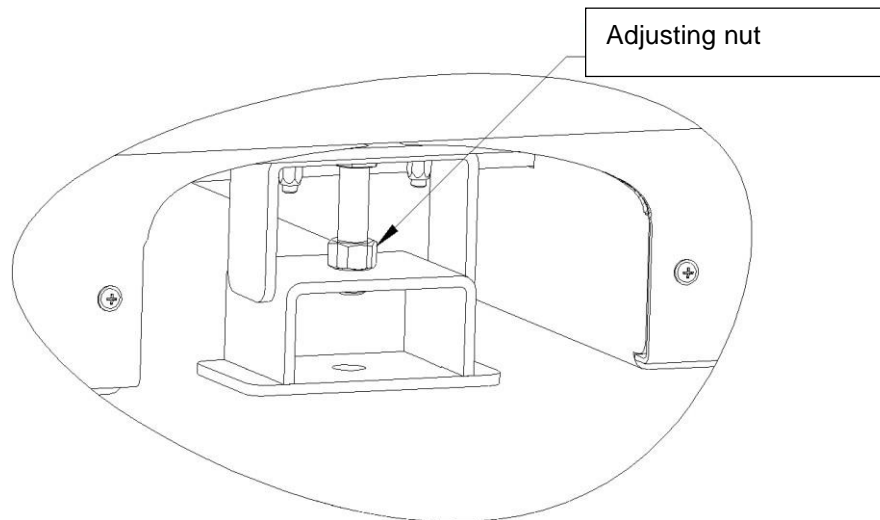

View of the leveling feet and the adjustment screw used to level the compressor.

SHOCK ABSORBERS MOUNTING

(performed by the user)

Screw compressor is equipped with shock absorbers which are delivered disassembled and must be mounted after unpacking the machine.

Follow the steps for mounting:

1. Read carefully the Compressor Operation Manual (in particular, Chapters 2 and 4 Part I, which deal with room requirements and minimum wall distance when positioning the compressor).
2. Dismantle the base cover plates (1) by unscrewing three fixing screws (2).
3. Lift the compressor off the pallet.
4. Attach the shock absorbers (3).
5. Place the compressor at its destination.
6. Level the compressor.
7. Install the base cover plates (1).

Attention!!! Take particular care when mounting the shock absorbers to the base.

Screw compressors: BSDF 18, BSDF 22

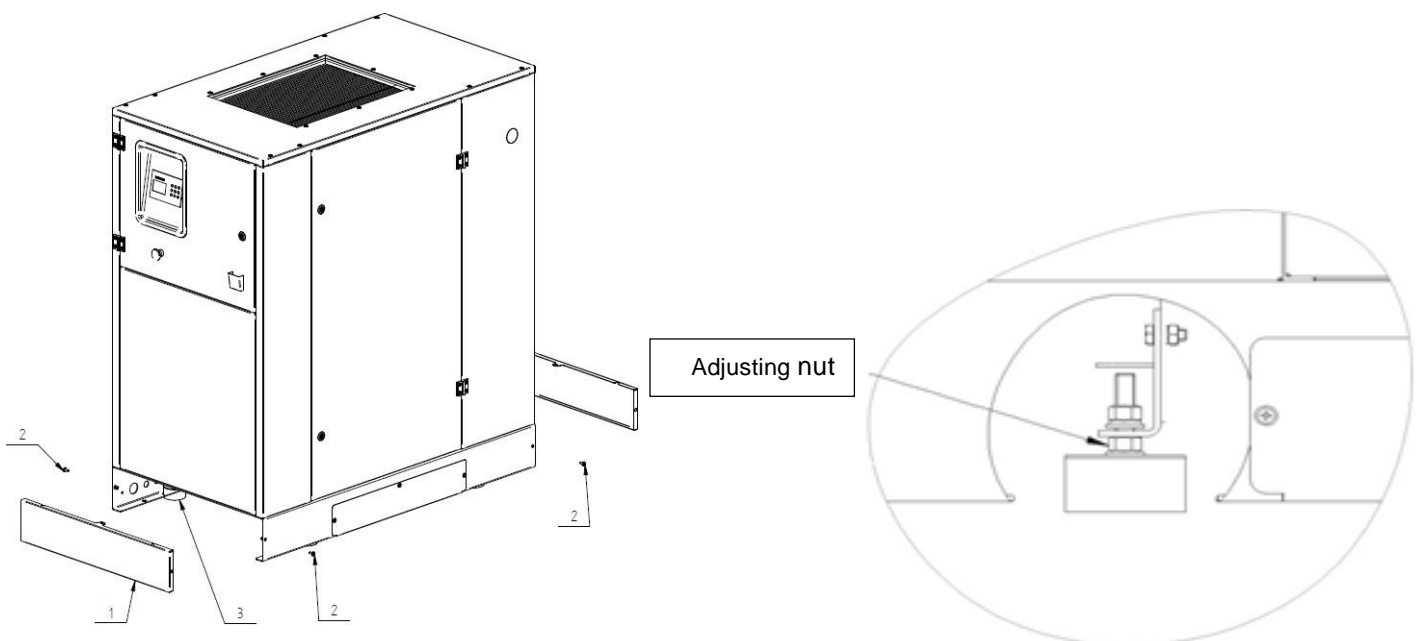

View of the shock absorber and the adjustment screw used to level the compressor.

**Screw compressors:
BSDF 30, BSDF 37, BSDF 45, BSDF 55**

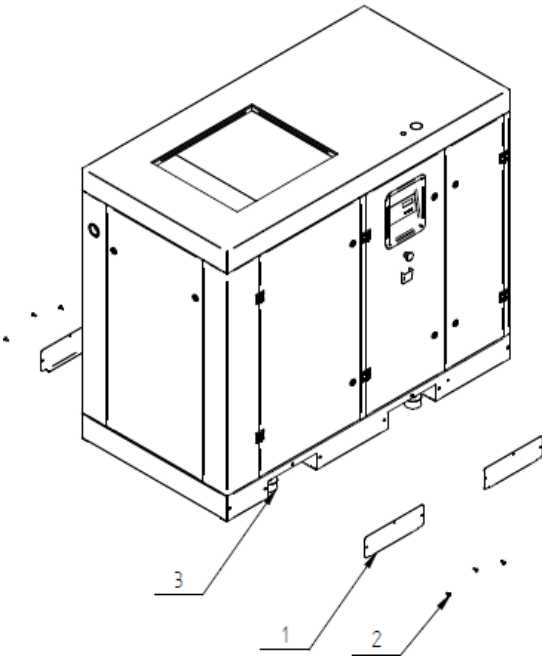

Screw compressors
BSDF 30, BSDF 37

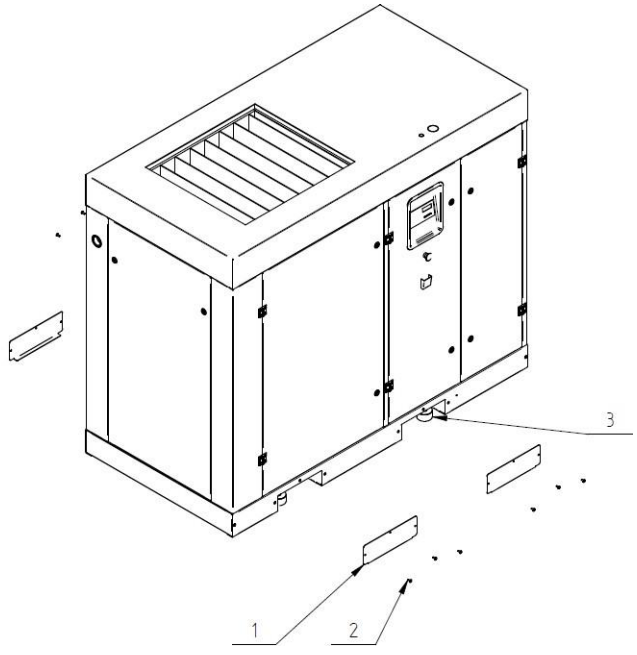

Screw compressors
BSDF 45, BSDF 55

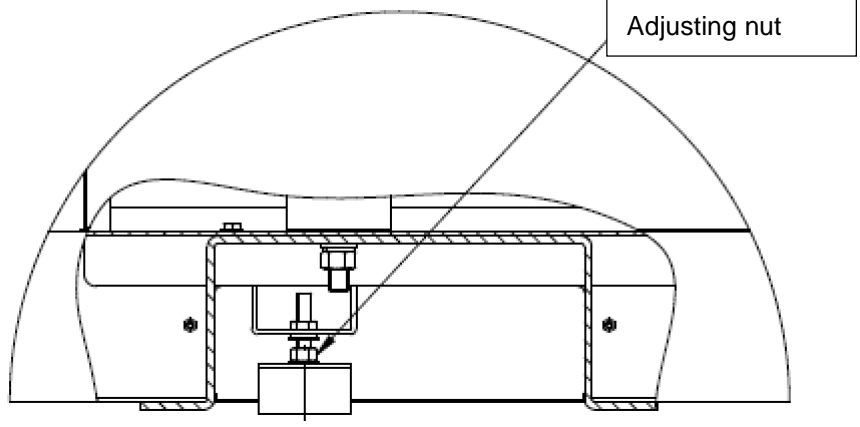

View of the shock absorber and the adjustment screw used to level the compressor.

EU-Konformitätserklärung / EC Declaration of Conformity

in according to machine guideline 2006/42/EC Appendix II.1.A

1. This declaration of conformity is issued under the responsibility of the manufacturer.
The manufacturer / distributor
BERG KOMPRESSOREN GmbH
Medienstraße 35, 47807 Krefeld, Deutschland
2. Hereby declares that the following product.
Product description: oil injected screw compressor for generating compressed air @7 to15bar
Serial no.:
Trade name / type description: KOMPBERG® BSDF
BSDF22, BSDF30, BSDF37, BSDF45, BSDF55, BSDF75, BSDF90, BSDF110, BSDF132, BSDF160, BSDF185, BSDF200, BSDF250, BSDF305
3. meets all relevant provisions of the above stated guideline and the other applied guidelines, in the design supplied by us conforms with the following relevant regulations
2014/68/EU Pressure Equipment Directive;
2014/30/EU Electromagnetic compatibility Directive;
2014/35/EU Low Voltage Directive;
2006/42/EU Machinery Directive;
4. In the event of the machine undergoing modification without our agreement, this loses its validity.
5. The following harmonised standards were applied, in its current version:
EN 1012-1:2011
EN IEC 6100-6-4:2019
EN 60204-1:2018
EN ISO 12100:2012
EN ISO 13849-1-2
Compressors and vacuum pumps - Safety requirements - Part 1: Compressors
Simple unfired pressure vessels designed to contain air- Part 1: Pressure vessels for general purposes
Safety of machinery - Electrical equipment of machines - Part 1: General requirements
Safety of machinery - General principles for design - Risk assessment and risk reduction
Safety of machinery -Safety relevant parts of controls - Part 1: General principles for design
Safety of machinery -Safety relevant parts of controls - Part 2: Validation
6. Documentation provided by:
BERG KOMPRESSOREN GmbH
47807 Krefeld, Germany

Date: 24.05.2022,

Signaturare